

ROTOR

switzerland



Gefederte ROTOR-Spitzen mit Druckanzeige

Spring loaded with pressure indicator

Pointes à ressort et indication de pression

Anwendungsbereich

Die Druckanzeige durch Farbringe ermöglicht eine schnelle Einstellung und Überwachung des optimalen Anstelldruckes. Bei fester Positionierung werden Längentoleranzen und unterschiedliche Zentrierbohrungen durch den Federweg kompensiert. Leichte Werkstücke können entsprechend fein gespannt werden. Sämtliche Spitzen mit Druckanzeige sind in 2 Federstärken erhältlich.

Application

A pressure indicator with different color bands permits rapid setting and monitoring of the optimum pressure. Length tolerances and different centre bores are compensated through a travel stroke at fixed positions. Correspondingly light workpieces can be clamped very fine. All Centres with pressure indicator are available in two different spring pressures.

Utilisation

L'indication de pression des anneaux colorés permet un réglage et un contrôle de la pression optimale. Tolérances de longueur et différents diamètres de centrage sont compensés par une force d'appui en positions fixes. En conséquence des pièces légères peut être finement guidées. Toutes les pointes avec indication de pression sont en vente en 2 différentes forces de ressort.

Type DA-N

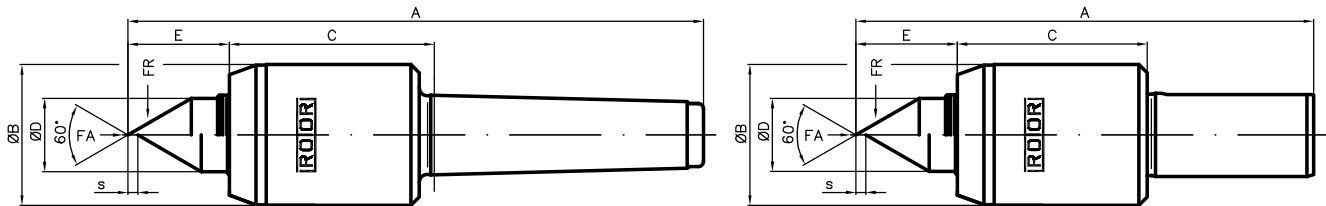

Ausführung Model modèle	Best. Nr. Order No. no. de com.	FA		FR		Best. Nr. Order No. no. de com.		FA		FR		Abmessungen Dimensions dimensions						Werkstück Workpiece pièce max. kg	n max RPM max n max min ⁻¹
		daN	daN	daN	daN	daN	daN	A	B	C	D	E	s						
MK MT CM	2	0241	11-110	24-240	0241-S	3-33	8-75	136	34	53	14	19	2.7	190	7000				
	3	0341	20-200	40-420	0341-S	7-70	15-150	174	42	62	22	31	3	440	5800				
	4	0441	23-230	50-500	0441-S	11-110	25-240	209	53	72	28	34	4.3	900	4800				
	5	0541	80-800	150-1500	0541-S	30-280	60-600	259	64	87	38	42	5.2	1850	4000				
Zyl. cyl. cyl.	Ø20x40	2051	11-110	24-240	2051-S	3-33	8-75	108	34	48	14	19	2.7	190	7000				
	Ø25x50	2551	20-200	40-420	2551-S	7-70	15-150	139	42	58	22	31	3	440	5800				
	Ø1"x2"	0151	20-200	40-420	0151-S	7-70	15-150	139	42	58	22	31	3	440	5800				
	Ø32x63	3251	23-230	50-500	3251-S	11-110	25-240	165	53	68	28	33	4.3	900	4800				
VDI	20	2061	11-110	24-240	2061-S	3-33	8-75	108	34	48	14	19	2.7	190	7000				
	30	3061	20-200	40-420	3061-S	7-70	15-150	144	42	58	22	31	3	440	5800				
	40	4061	23-230	50-500	4061-S	11-110	25-240	165	53	68	28	34	4.3	900	4800				
	50	5061	80-800	150-1500	5061-S	30-280	60-600	201	64	81	38	42	5.2	1850	4000				

DA-K-Set / DA-K-Set / DA-K-Assortiment

Ausheber / Extractor / Extracteur

Ausführung Model modèle	Best. Nr. Order No. no. de com.	Best. Nr. Order No. no. de com.	
			→ 
MK MT CM	2	0247-00	0247-S-00
	3	0347-00	0347-S-00
	4	0447-00	0447-S-00
	5	0547-00	0547-S-00
Zyl. cyl. cyl.	Ø20x40	2057-00	2057-S-00
	Ø25x50	2557-00	2557-S-00
	Ø1"x2"	0157-00	0157-S-00
	Ø32x63	3257-00	3257-S-00
VDI	20	2067-00	2067-S-00
	30	3067-00	3067-S-00
	40	4067-00	4067-S-00
	50	5067-00	5067-S-00

Passend zu Suitable for convenant p.	Best. Nr. Order No. no de commande
2 ST-3 SM	0217-20
3 ST-5 SM	0317-20
5 ST	0517-20



Rotierende Aufnahme, Ausheber und folgende Einsätze
Live-Centre type K, extractor and following points
Contre pointes tournantes type K, extracteur et pièces Interchangeables

01 / 02 / 03 / 05 / 07 / 10

Type DA-K

Ausführung Model modèle	Best. Nr. Order No. no. de com.	Best. Nr. Order No. no. de com.	Abmessungen Dimensions dimensions			Einsätze Inserts éléments	
			D1	D2	L1		
MK MT CM	2	0247-00	0247-S-00	7	14	7	0217-01/10
	3	0347-00	0347-S-00	12	22	9	0317-01/10
	4	0447-00	0447-S-00	15	28	10	0417-01/10
	5	0547-00	0547-S-00	22	38	11	0517-01/10
Zyl. cyl. cyl.	Ø20x40	2057-00	2057-S-00	7	14	7	0217-01/10
	Ø25x50	2557-00	2557-S-00	12	22	9	0317-01/10
	Ø1"x2"	0157-00	0157-S-00	12	22	9	0317-01/10
	Ø32x63	3257-00	3257-S-00	15	28	10	0417-01/10
VDI	20	2067-00	2067-S-00	7	14	7	0217-01/10
	30	3067-00	3067-S-00	12	22	9	0317-01/10
	40	4067-00	4067-S-00	15	28	10	0417-01/10
	50	5067-00	5067-S-00	22	38	11	0517-01/10

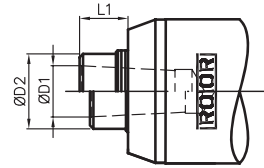

Gehäuseabmessungen, FA/FR-Werte und Drehzahlen siehe Typ DA-N.

Dimensions of the body, FA/FR and RPM data see type DA-N.

Dimensions de corps, FA/FR et nombres de tours voir type DA-N.

Einsätze mit Kegel 1:10

Interchangeable Points 1:10

Pointes interchangeables 1:10

Passend zu Suitable for convenant p.	Einsatz Inserts élément	Best. Nr. Order No. no. de com.	Abmessungen Dimensions dimensions								
			d1	l	A	B	C	D	E	F	
2 ST + 3 SM	01	0217-01	7	18	15	17					
	02	0217-02	7	18	14	20	5				
	03	0217-03	7	18	26	19	11		7	3	
	05	0217-05	7	18	14	28	3.8	10			
	06	0217-06	7	18	14	28	4.8	12			
	07	0217-07	7	18	14	28	5.8	14			
	08	0217-08	7	18	14	28	7.8	16			
	09	0217-09	7	18	14	10	6		4	2	
	10	0217-10	7	18	20	20			16	6	
	3 ST + 4 SM	01	0317-01	12	24	25	28				
02		0317-02	12	24	21	32	6				
03		0317-03	12	24	45	29	22		8.2	3.2	
05		0317-05	12	24	21	40	4.8	12			
06		0317-06	12	24	21	40	5.8	14			
07		0317-07	12	24	21	40	7.8	16			
08		0317-08	12	24	21	40	9.4	18			
09		0317-09	12	24	21	17	7.2		4	2	
10		0317-10	12	24	26	26			20	7	
4 ST + 5 SM		01	0417-01	15	30	30	34				
	02	0417-02	15	30	26	38	8				
	03	0417-03	15	30	55	34	28		12	4	
	05	0417-05	15	30	26	49	5.8	15			
	06	0417-06	15	30	26	49	7.8	17			
	07	0417-07	15	30	26	49	9.4	19			
	08	0417-08	15	30	26	49	11.8	22			
	09	0417-09	15	30	26	22	9		5	2.5	
	10	0417-10	15	30	40	39			34	11	
	5 ST	01	0517-01	22	35	38	43				
02		0517-02	22	35	38	57	11				
03		0517-03	22	35	68	42	36		22	6	
05		0517-05	22	35	38	68	7.8	17			
06		0517-06	22	35	38	68	9.4	19			
07		0517-07	22	35	38	68	11.8	22			
08		0517-08	22	35	38	68	14.2	27			
09		0517-09	22	35	38	31	13		8	3	
10		0517-10	22	35	61	58			55	20	

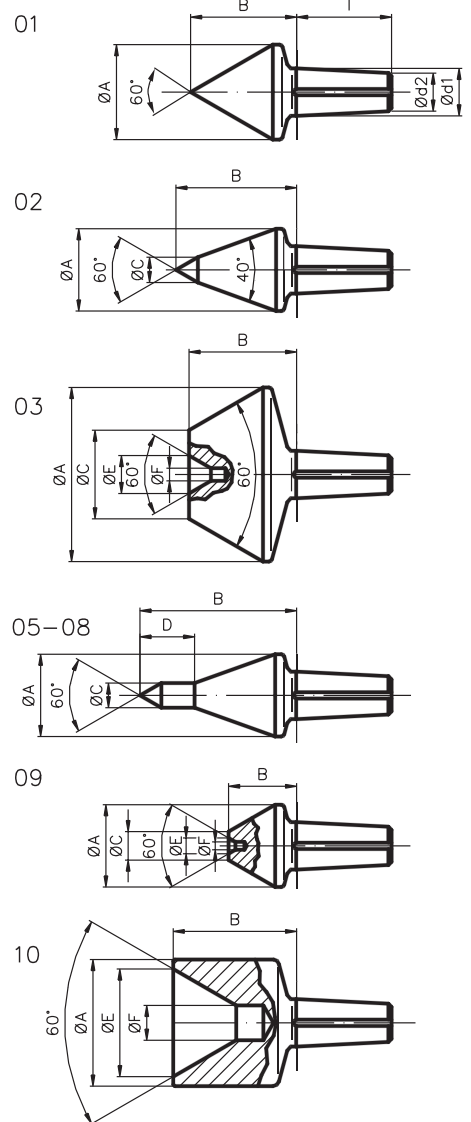

Type DA-V

Ausführung Model modèle	Best. Nr. Order No. no. de com.	Best. Nr. Order No. no. de com.	Abmessungen Dimensions dimensions			
			D	H	P	
MK MT CM	2	0242	0242-S	14	22	8
	3	0342	0342-S	22	35	10
	4	0442	0442-S	28	41	14
	5	0542	0542-S	38	51	15
Zyl. cyl. cyl.	Ø20x40	2052	2052-S	14	22	8
	Ø25x50	2552	2552-S	22	35	10
	Ø1"x2"	0152	0152-S	22	35	10
	Ø32x63	3252	3252-S	28	41	14
VDI	20	2062	2062-S	14	22	8
	30	3062	3062-S	22	35	10
	40	4062	4062-S	28	41	14
	50	5062	5062-S	38	51	15

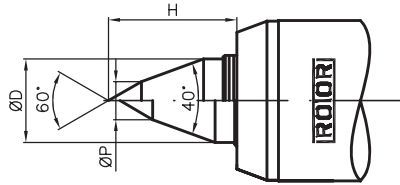

Gehäuseabmessungen, FA/FR-Werte und Drehzahlen siehe Typ DA-N.

Dimensions of the body, FA/FR and RPM data see type DA-N.

Dimensions de corps, FA/FR et nombres de tours voir type DA-N.

Type DA-L

Ausführung Model modèle	Best. Nr. Order No. no. de com.	Best. Nr. Order No. no. de com.	Abmessungen Dimensions dimensions				
			D	E	H	P	
MK MT CM	2	0248	0248-S	14	28	12	5.8
	3	0348	0348-S	22	43	16	7.8
	4	0448	0448-S	28	51	19	9.8
	5	0548	0548-S	38	62	22	11.8
Zyl. cyl. cyl.	Ø20x40	2058	2058-S	14	28	12	5.8
	Ø25x50	2558	2558-S	22	43	16	7.8
	Ø1"x2"	0158	0158-S	22	43	16	7.8
	Ø32x63	3258	3258-S	28	51	19	9.8
VDI	20	2068	2068-S	14	28	12	5.8
	30	3068	3068-S	22	43	16	7.8
	40	4068	4068-S	28	51	19	9.8
	50	5068	5068-S	38	62	22	11.8

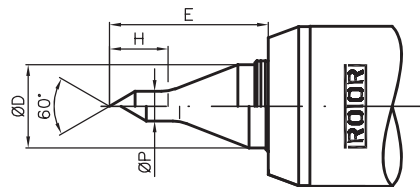

Gehäuseabmessungen, FA/FR-Werte und Drehzahlen siehe Typ DA-N.

Dimensions of the body, FA/FR and RPM data see type DA-N.

Dimensions de corps, FA/FR et nombres de tours voir type DA-N.

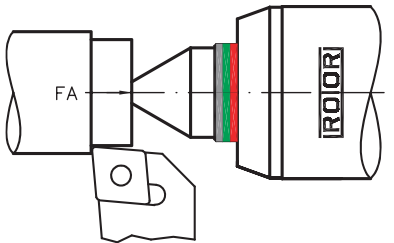

Leichte Werkstücke und geringe Spanabnahme
= schwache Spannkraft
Light workpiece and low stock removal
= low pressure

pièces légères et passes réduites
= pression faible

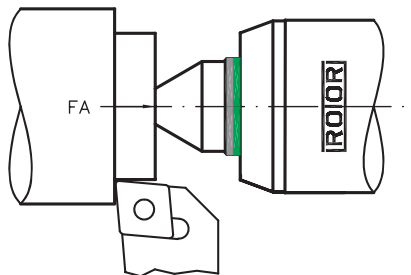

mittlere Werkstücke und mässige Spanabnahme
= mittlere Spannkraft
medium workpiece and moderate stock removal
= medium pressure

pièces moyennes et passes moyennes
= pression moyenne

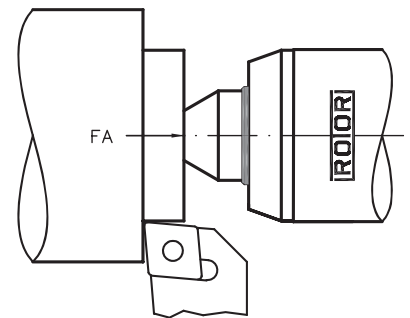

schwere Werkstücke und starke Spanabnahme
= hohe Spannkraft

heavy workpiece and heavy stock removal
= high pressure

pièces lourdes et passes profondes
= pression forte