

**GOOD CONNECTIONS
FOR ANY JOB**

THE RH135 HYDRA
GRINDING SYSTEM

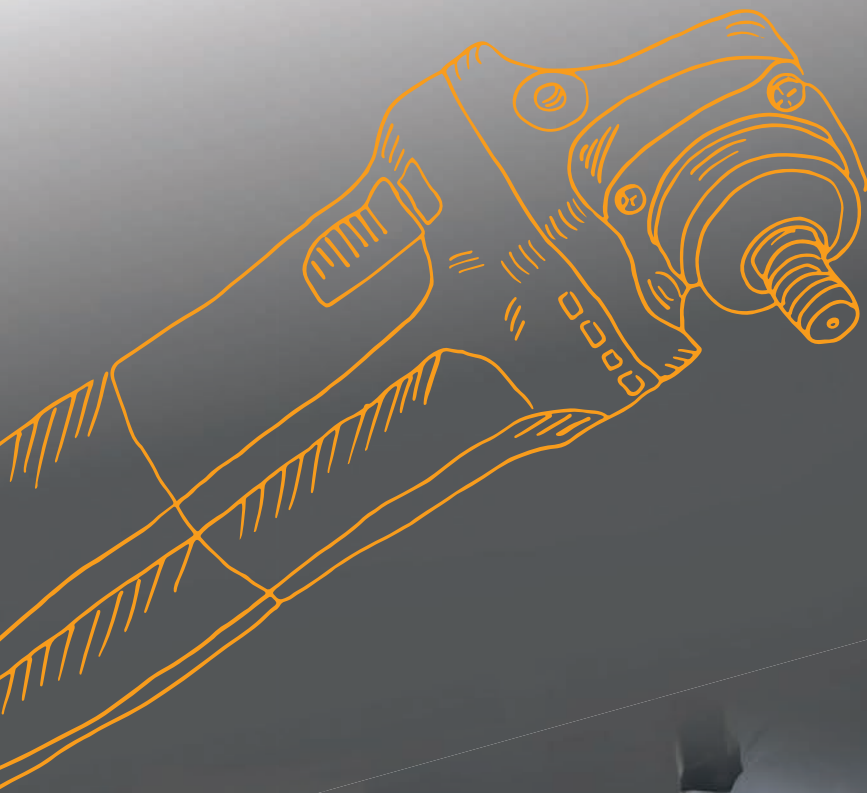

RHODIUS

AN ALL-ROUNDER
WITH GOOD CONNECTIONS.



ONE SYSTEM FOR ALL

1 system • 3 attachments • 5 applications



Versatility now has a new name: RH135 HYDRA. The innovative new system from RHODIUS is a real quick-change artist. The various attachments can be connected in just a few seconds, ensuring that just one machine is needed for a wide range of applications that would normally all need a dedicated machine. This doesn't just save time: it also improves working speed and makes real savings by reducing the outlay on separate machinery.

The HYDRAattachment system fits industry-standard angle grinders (adjustable, 125 mm Ø), and is compatible with compressed-air systems and flexible shafts.

Your benefits:

- Simple, tool-less assembly
 - Work with just one system
 - No lugging cases about
 - No messy pile of tools
- Read on to discover all of the advantages!

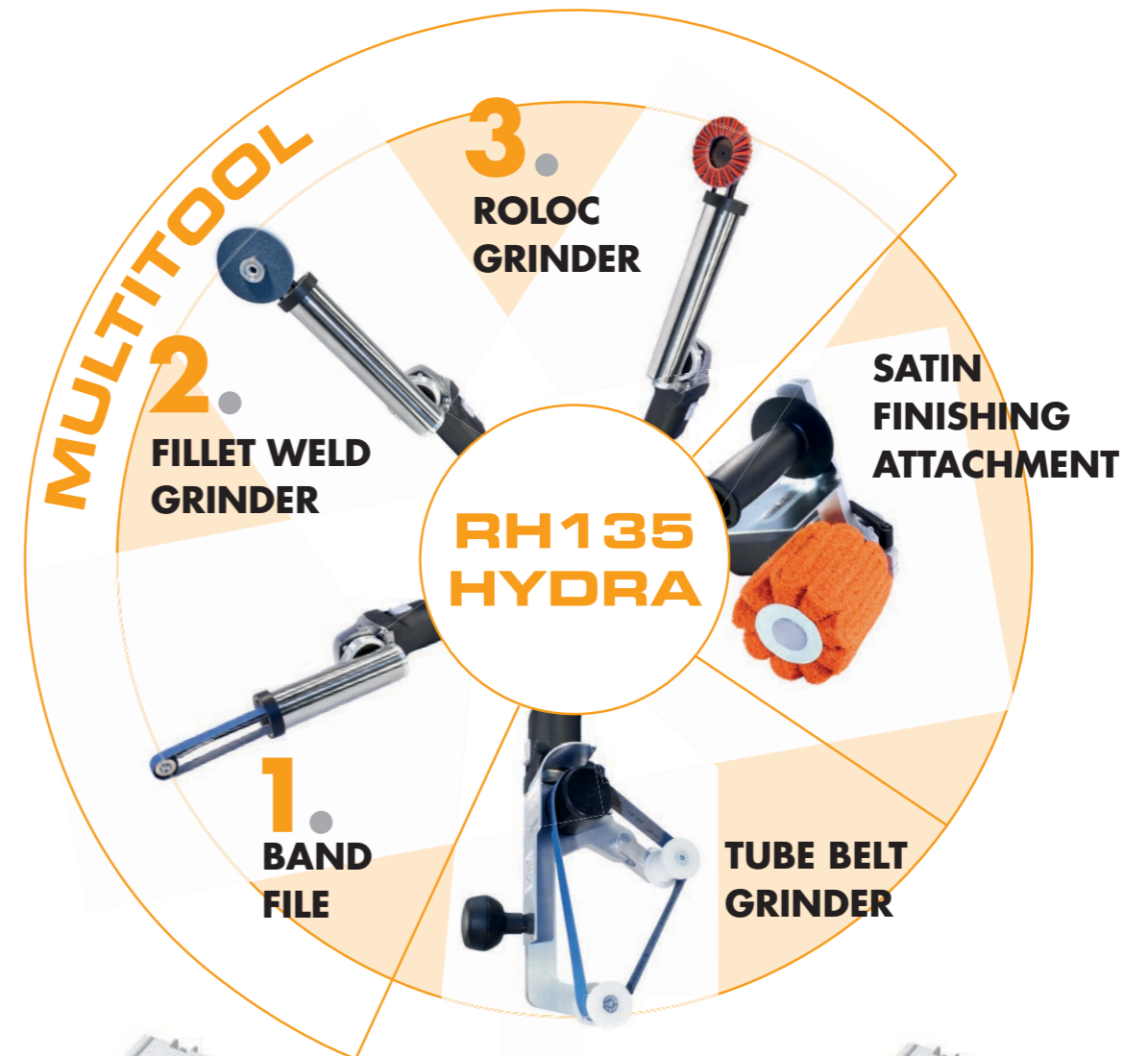

THE ALL-IN-ONE SET

NEW!

RH135 HYDRA ALL-IN-ONE SET

	Dimensions			Product category	€/pc.	GTIN/pc. EAN/pc.
RH135 HYDRA All-in-One Set		1	304451	PKSON		4011890113318

Set contents:

- | | |
|-----------------------------------|--|
| 1x MultiTool attachment | 1x MultiTool starter set |
| 1x tube belt grinder attachment | 1x tube belt grinder starter set |
| 1x satin finishing attachment | 1x satin finishing starter set |
| 2x L-Box 136 case | 1x mitre grinding starter set |
| 1x case insert for attachments | 1x corner fillet weld grinding starter set |
| 1x anti-slip mat for starter sets | Adapter rings for various angle grinders |

THE MULTITOOL: BLAZE A NEW TRAIL.

MULTITOOL

1. BAND FILE ATTACHMENT



- **High-quality, rugged yet lightweight attachment**
- **Takes bands with industry-standard dimensions** (width: 6–15 mm; length: 520, 533, 610 and 650 mm)
- **Slimline design** makes it ideal for working on hard-to-reach areas
- **Straight band guide** reduces load on band latches
- **Better working safety and improved handling** thanks to a protective tube
- **Concave and cross-knurled drive roller** ensures absolutely centric band movement
- **Optimal spring tension** effectively prevents the abrasive belt from slipping off
- **New quick-release system** ensures user-friendly replacements of contact arm and protective tube

MULTITOOL

2. FILLET WELD GRINDER ATTACHMENT



- **High-quality, rugged yet lightweight attachment**
- **Patented, low-profile multi-function roller (35 mm)** permits work at tight angles, such as on assembled handrails
- **Ball bearing** with double bearing and dust protection
- **Slimline design plus small press-fit compact discs (90 mm Ø)** permit work on hard-to-reach areas – as is the case with fillet welds, for example
- **Better working safety and improved handling** thanks to protective tubing over the drive belt



High-precision work even on hard-to-reach areas

Easy to use even on hard-to-reach areas



THE MULTITOOL FOR THE PERFECT FINISH.

MULTITOOL

3. ROLOC GRINDER ATTACHMENT



- High-quality, rugged yet lightweight attachment
- Patented, low-profile multi-function roller (35 mm) permits work on hard-to-reach areas
- Simple quick-release system for short setup times
- A wide range of applications in tool, mould and model making, machinery manufacturing, and container, aircraft and engine construction
- Fits directly onto the angle grinder's M14 threaded spindle with the corresponding adapter

MULTITOOL



High-precision work even on hard-to-reach areas

MULTITOOL

- 1 drive system = 3 application scenarios
- New, efficient grinding system
- Wide range of grinding applications

MULTITOOL

	Dimensions			Product category	€/pc.	GTIN/pc. EAN/pc.
MultiTool attachment		1	304445	PKSON		4011890113257
MultiTool starter set		1	304442	PK07		4011890113226

MultiTool starter set contents:

- 1x HRB QUICK 70 x 12 mm, 120 grain, Fine
- 1x SVS QUICK D51 mm, orange
- 1x VSK QUICK 76 mm, A-Medium
- 3x KFK QUICK D51 mm, 80 grain
- 1x compact non-woven VKS KN 90 x 3 x 20 mm, H 7, medium-hard
- 1x compact non-woven VKS KN 90 x 6 x 20 mm, H 5, soft
- 1x elastic grinding block 35 x 60 x 30 mm, 24 H
- 2x non-woven roller VLSR V 25 x 600 mm, yellow
- 2x abrasive belt ESB KX FLEX 6 x 650 mm, 80 grain
- 2x abrasive belt ESB T 6 x 650 mm, A 160 (120 grain)
- 1x abrasive belt ESB V 6 x 650 mm, A-Medium



THE CONNECTION FOR A GOOD GUIDE.

TUBE BELT GRINDER ATTACHMENT



- High-quality, rugged yet lightweight attachment
- Very easy working on tubes
- Enables grinding on hard-to-reach areas such as assembled handrails (5 cm wall spacing)
- Various widths of band can be used (6–35 mm)
- Dust-protected ball bearings
- Patented guide rollers
- Fixed side discs on the guide rollers ensure that the abrasive belt always runs true. This makes it almost impossible for the abrasive belt to slip off.

TUBE BELT GRINDER ATTACHMENT

	Dimensions			Product category	€/pc.	GTIN/pc. EAN/pc.
Tube belt grinder attachment		1	304446	PKSON		4011890113264
Tube belt grinder starter set		1	304450	PK07		4011890113301

Tube belt grinder starter set contents:

- 2x abrasive belt ESB CL 35 x 650 mm, 80 grain
- 2x abrasive belt ESB T 35 x 650 mm, A 160 120 grain
- 1x abrasive belt ESB V 35 x 650 mm, A-Medium
- 2x abrasive belt ESB KX FLEX 15 x 650 mm, 80 grain
- 2x abrasive belt ESB T 15 x 650 mm, A 160 120 grain
- 1x abrasive belt ESB V 15 x 650 mm, A-Medium

The belt is always guided perfectly thanks to fixed side discs on the guide rollers.

THE CONNECTION FOR A BETTER SHINE.

SATIN FINISHING ATTACHMENT



- High-quality, rugged yet lightweight attachment
- Various sizes of satin finishing rollers can be used (up to 125 mm Ø)
- Revolutionary new mandrel enables rapid changing of rollers
- Quiet running thanks to spring-mounted mandrel
- Mandrel with Roloc mount
- Fits to all industry-standard satin finishing rollers (19 mm; 1-, 2- and 4-groove systems)
- Felt Roloc disc fitted to the front avoids accidental damage when working at an angle (e.g. on angled sections)

Flexible spring-mounted groove system

Can be used on 1-, 2- and 4-groove systems!



Felt Roloc discs avoid accidental damage when working at an angle

RH124
WORLD FIRST

SATIN FINISHING ATTACHMENT

	Dimensions			Product category	€/pc.	GTIN/pc. EAN/pc.
Satin finishing attachment		1	304444	PKSON		4011890113240
Satin finishing starter set	100 x 100 x 19	1	304447	PK07		4011890113271
RH124 satin finishing mandrel		1	304443	PK07		4011890113233

Satin finishing starter set contents:

- 1x roller VFW 100 x 100 x 19 mm, orange (COARSE, 80 grain)
- 1x PF QUICK D51 mm diameter
- 1x RH124 satin finishing mandrel

STARTER SETS FOR SPECIAL APPLICATIONS.

Special starter sets perfectly tailored to the typical working conditions and requirements when performing mitre grinding and corner fillet weld grinding – guaranteeing efficient work and uniform workmanship for every application.

MITRE GRINDING SET



MITRE GRINDING SET						
	Dimensions			Product category	€/pc.	GTIN/pc. EAN/pc.
Mitre grinding starter set	125	1	304448	PK07		4011890113288

Mitre grinding starter set contents:

- 2x self-fastening disc KGK V 125 mm, 120 grain
- 2x self-fastening disc KGT V 125 mm, A 100 (220 grain)
- 2x self-fastening disc KGT V 125 mm, A 45 (400 grain)
- 1x roller VFW 125 x 50 x M14 thread, orange (Coarse, 80 grain)
- 1x backing pad RHST V 125 x 08 x M14, hard
- 1x backing pad RHST V 125 x 15 x M14, medium
- 1x stainless steel adhesive tape EB 100 x 200 mm

CORNER FILLET WELD STARTER SET

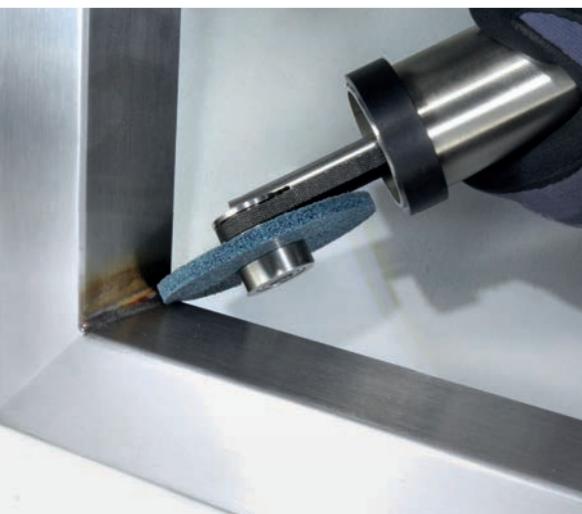

CORNER FILLET WELD STARTER SET						
	Dimensions			Product category	€/pc.	GTIN/pc. EAN/pc.
Corner fillet weld grinding starter set	125	1	304449	PK07		4011890113295

Corner fillet weld starter set contents:

- 1x flap disc VSK F 125 mm, A-Medium/80 grain
- 1x unitised disc VVKS KN 125 x 3 x 22 mm, H7 medium-hard
- 1x unitised disc VKS KN 125 x 6 x 22 mm, H5 soft
- 1x non-woven roller VLSR V 40 x 600 mm, yellow (180–240 grain)

OUR MOST VERSATILE PRODUCT WITH COUNTLESS ADVANTAGES.

It's time for what matters: simple, efficient working.

The RH135 HYDRA consigns the tiresome, time-consuming process of swapping between machines during a multi-stage job to history – and with it the thankless task of lugging several cases around. All attachments and abrasive starter sets can be supplied in practical, stackable cases (L-Boxes), letting you handle a wide range of grinding jobs with only a moderate number of tools and toolboxes. It only takes a few seconds to become a real all-rounder!

Interested?

You can read more about our many product innovations in our New Products brochure: request your copy today from service@rhodius.de

Your benefits

- Reduces the number of drive systems needed (1 drive system + 3 attachment sets = 5 applications)
5 separate drive systems would normally be needed: band file, fillet weld grinder, tube belt grinder, Roloc grinder and satin finishing machine
- Low procurement and repair costs
- Cost savings approximately EUR 1,500–2,000
- Cuts down on machine cases during assembly work
- Simple, tool-less assembly
- Wide range of possible applications
- Work at tight angles and on hard-to-reach areas
- Manufactured and patented in Germany

SAVINGS OF UP TO

EUR 2,000

Would you also like to experience our RH135 HYDRA all-rounder in action?

Reserve your appointment today for a hands-on demo of the RH135 HYDRA in our RHODIUS Competence Centre: rcc@rhodius.de

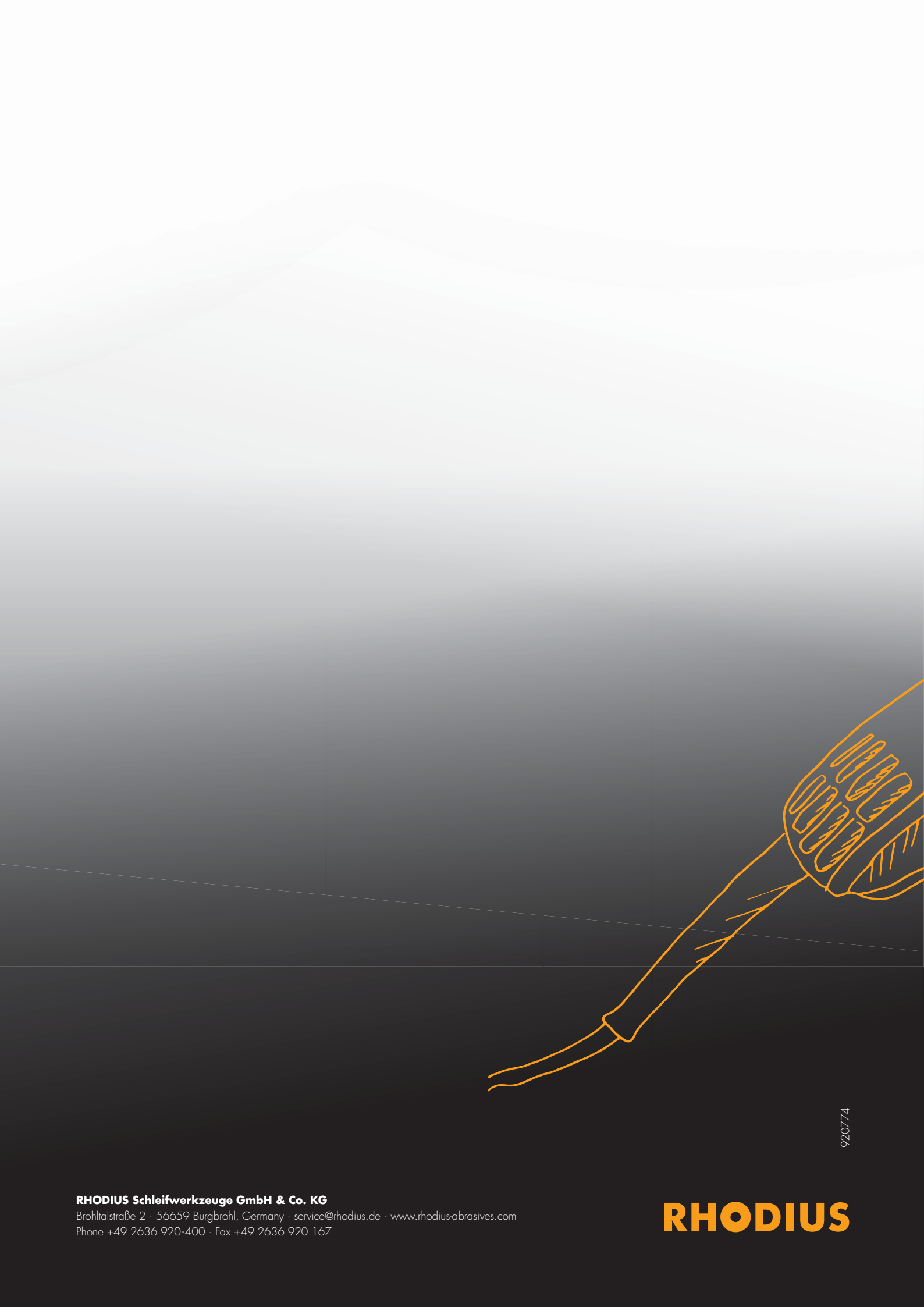

920774

RHODIUS Schleifwerkzeuge GmbH & Co. KG

Brohltalstraße 2 · 56659 Burgbrohl, Germany · service@rhodius.de · www.rhodius-abrasives.com
Phone +49 2636 920-400 · Fax +49 2636 920 167

RHODIUS