

NEU/NEW

MESSERKÖPFE UND FRÄSPLATTEN  
MILLING HEADS AND INSERTS



**SCHWARZ** GmbH  
Vollhartmetall Präzisionswerkzeuge

Unsere Leistungen bestehen aus Planung, Konstruktion, 3D-Simulation, Herstellung und Qualitätskontrolle von Präzisionswerkzeugen.

Wir sind spezialisiert auf Dreh- und Fräswerkzeuge, HPC-Fräser und HPC-Bohrer. Gerne verwirklichen wir Ihnen auch spezielle Anfertigungen von Präzisionswerkzeugen.

*Our services consist of planning, construction, 3D-simulation, manufacturing and quality control of high precision tools.*

*We are specialized in Turning, Milling, Threading, HPC Endmills and HPC Drills. We are also happy to realize any wishes for special tools.*



In unserem hochmodernen Maschinenpark benutzen wir ausschließlich CNC-Schleifzentren der neuesten Generation, von namhaften Herstellern wie Walter und Saake. Durch Messmaschinen der Firma Zoller, sind wir in der Lage, Ihre Bedürfnisse von Präzisions- und Sonderwerkzeugen so schnell wie möglich zu realisieren.

*In our machine park, we exclusively use CNC grinding centers of the latest generation from well-known manufacturers such as Walter and Saake.*

*Due to our measuring machines from Zoller, we are able to realize your needs of precision and special tools as quickly as possible.*

# SCHWARZ

**SCHWARZ** ist ein Hersteller von hochpräzisen und langlebigen Zerspanungswerkzeugen. Namhafte Unternehmen der Automobilbranche sowie Unternehmen aus der Luft- und Raumfahrttechnik zählen zu unseren Kunden. Wir möchten Ihnen unsere Qualität und Technologie näher bringen und stehen Ihnen gerne auch bei der Auswahl und Verwendung unserer Werkzeuge mit Rat und Tat zur Seite.

Unsere Werkzeuge werden nach DIN ISO 9001:2008 gefertigt und erfüllen somit alle Industriestandards. Wir entwickeln sie stetig weiter, damit wir unsere Kunden mit zeitgemäßen Arbeitsmitteln ausstatten können.

**SCHWARZ** garantiert Ihnen ausgezeichnete Qualität und hohe Standzeiten. Mit dem Kauf unserer Werkzeuge leisten Sie außerdem einen wertvollen Beitrag zum Schutz unserer Umwelt, da wir bei der Herstellung ausschließlich grüne, saubere Technologien einsetzen.

Wir freuen uns darauf, demnächst auch Sie von unserer Kompetenz überzeugen zu dürfen!

***SCHWARZ** is a producer of high-precision and long-lasting cutting tools. Among our customers, there are well-known companies from the automobile industry as well as such from the aerospace technology. We would like to present our quality and technology to you by providing technical support from the choice to the usage of our tools.*

*Our tools are produced in accordance with DIN ISO 9001:2008 and thereby all industry standards are fulfilled. Furthermore, they are always in development enabling us to meet our customer's contemporary needs.*

***SCHWARZ** guarantees you an excellent quality and very high durability. Buying our tools also means to protect our environment through the exclusive use of clean and green technologies during the production process.*

*We look forward to an opportunity to convince you of our competence, too!*

**FORCE  LINE - PLANFRÄSEN 45° (FACE MILLING 45°)**

<b>ONSW...AM...</b>	<b>SW136-50...136-160</b>	6
<b>ONSW...AM...</b>	<b>SW137-50...137-125</b>	6
<b>SESW...AM12...</b>	<b>SW100-50...SW100-100</b>	10
<b>PDSW...AM12...</b>	<b>SW102-66...SW102-100</b>	10
<b>SESW...AM13...</b>	<b>SW101-50...SW101-125</b>	11
<b>HPSW...WS...</b>	<b>SW120-40-1</b>	16
<b>HPSW...AM...</b>	<b>SW120-40-2...SW120-125</b>	16
<b>HNKU...AM08...</b>	<b>SW141-40...141-80</b>	20
<b>SOSW...</b>	<b>SW151-40...151-125</b>	24
<b>SOSW...</b>	<b>SW152-40...152-160</b>	24

**FORCE  LINE - PLANFRÄSEN / PROFILFRÄSEN (FACE MILLING / PROFILING)**

<b>SDMX, EOMT, RPMX</b>	<b>SW153-25-1...SW153-32-2</b>	30
<b>SDMX, EOMT, RPMX</b>	<b>SW154-40...SW154-100</b>	30
<b>SDMX, EOMT, RPMX</b>	<b>SW155-50...SW155-125</b>	31
<b>XDSW...TC...</b>	<b>SW103-10...SW103-42</b>	38
<b>XDSW...TC...</b>	<b>SW104-52...SW104-800</b>	38
<b>RP...RD...</b>	<b>SW146-20-1...SW146-32-2</b>	42
<b>RP...RD...</b>	<b>SW147-40...SW147-50</b>	42
<b>RP...RD...</b>	<b>SW148-25-1...SW148-32-2</b>	43
<b>RP...RD...</b>	<b>SW149-40...SW149-100</b>	43
<b>RP...RD...</b>	<b>SW150-50...SW150-125</b>	44
<b>RDSW...WS...</b>	<b>SW105-15-1...SW105-25-2</b>	51
<b>RDSW...TC...</b>	<b>SW106-15...SW106-42-2</b>	51
<b>RDSW...AM...</b>	<b>SW107-42... SW107-80-2</b>	52
<b>RN...RO...</b>	<b>SW143-63</b>	57

**FORCE  LINE - HOCHVORSCHUBFRÄSEN (HIGH-FEED)**

<b>XSW...WS...</b>	<b>SW115-16...SW119-35</b>	.....	64
<b>XSW...TC...</b>	<b>SW116-16...SW116-25</b>	.....	64
<b>XSW...AM...</b>	<b>SW118-40...SW119-80</b>	.....	65

**FORCE  LINE - ECKFRÄSEN (SHOULDER)**

<b>WNSW...WS...</b>	<b>SW132-20...SW133-32</b>	.....	72
<b>WNSW... AM04...</b>	<b>SW134-32...SW134-50</b>	.....	72
<b>WNSW... AM08...</b>	<b>SW135-50...SW135-160</b>	.....	73
<b>TOSW...WS...</b>	<b>SW108-20...SW110-32</b>	.....	76
<b>TOSW...TC...</b>	<b>SW109-20...SW109-32</b>	.....	76
<b>TOSW...AM...</b>	<b>SW111-40...SW111-63</b>	.....	77
<b>SDSW...WS...</b>	<b>SW112-25...SW114-32</b>	.....	80
<b>SDSW...AM...</b>	<b>SW113-40...SW114-80</b>	.....	80
<b>APSWE...WS10...</b>	<b>SW121-16-1...SW121-25-2</b>	.....	84
<b>APSWE...TC10...</b>	<b>SW122-16...SW122-25</b>	.....	84
<b>APSWE...AM10...</b>	<b>SW123-40...SW123-63</b>	.....	85
<b>APSWE...WS16...</b>	<b>SW124-25-1...SW124-40-2</b>	.....	90
<b>APSWE...AM16...</b>	<b>SW125-40...SW125-125</b>	.....	90
<b>LNKU...</b>	<b>SW142-50</b>	.....	94

<b>SCHNITTDATENBERECHNUNG (CUTTING DATA CALCULATION)</b>	.....	98
<b>LEISTUNGSBEDARFSBERECHNUNG (POWER REQUIREMENT CALCULATION)</b>	.....	99
<b>PROBLEMLÖSUNG (TROUBLESHOOTING)</b>	.....	100
<b>ISO-BEZEICHNUNGSSYSTEM (ISO-DESIGNATION SYSTEM)</b>	.....	102



**PRODUKTBEZEICHNUNG (PRODUCT IDENTIFICATION)**

**BEISPIEL (EXAMPLE): RDSW 42-PFM-TC 12-Z6-01**

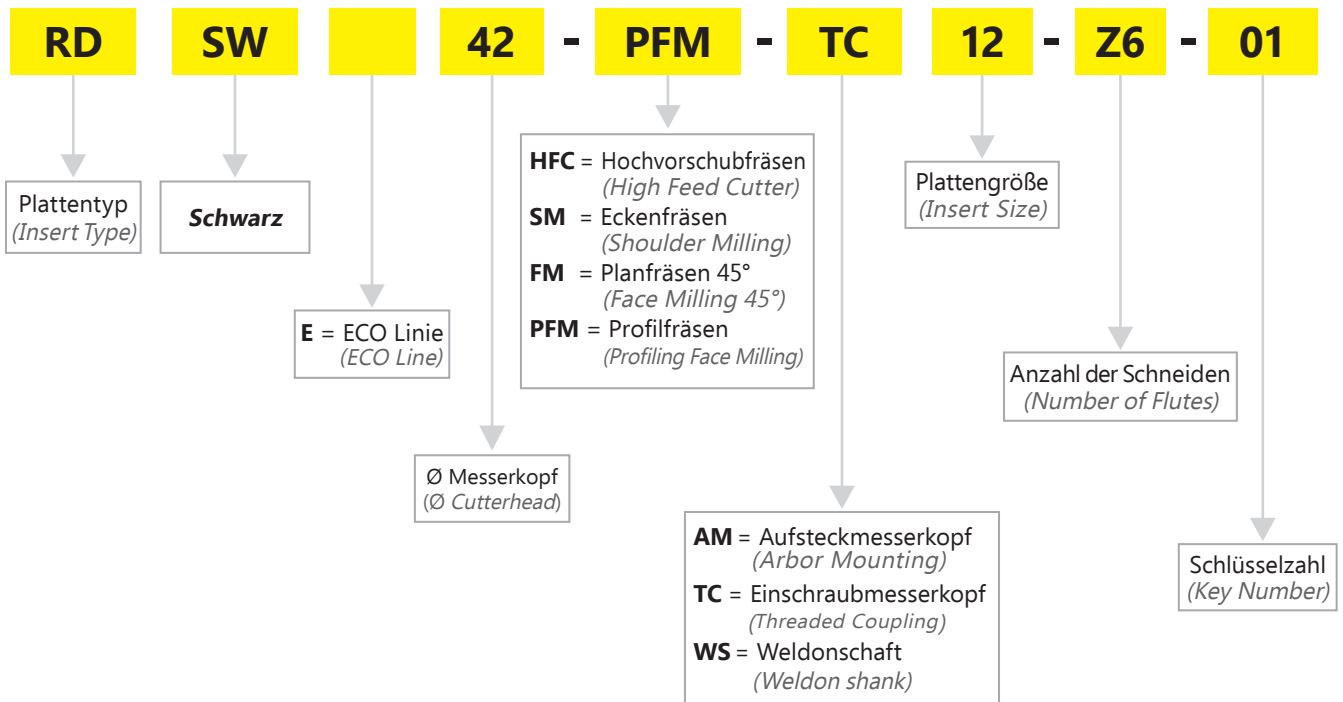

# FORCE LINE

**PLANFRÄSEN 45°**  
*(FACE MILLING 45°)*



# PLANFRÄSEN 45° SW136-137 (FACE MILLING 45° SW136-137)

## ONSW...AM...

Aufsteckmesserkopf  
(Arbor Mounting)

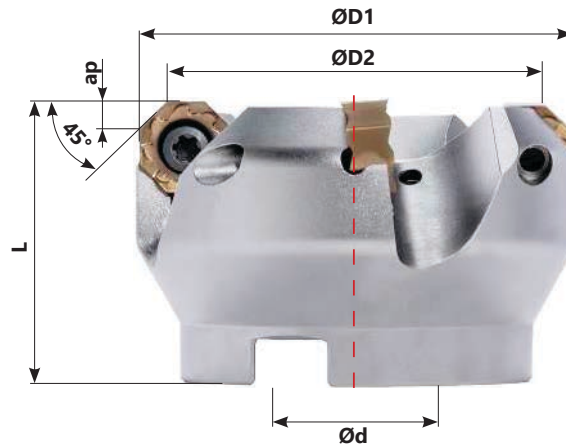

Bestellcode (Ordering Code)	Bezeichnung (Identification)	Platten (Inserts)		Maße (Dimensions) in mm					
		Typ (Type)	Anzahl (Number)	ØD1	ØD2	Ød	L	ap	
SW136-50	ONSNSW50-FM45-AM12-Z4-02	ON...12...	4	50	63	22	40	0,3-5,0	0,4-3,0
SW136-63	ONSNSW63-FM45-AM12-Z6-02	ON...12...	6	63	76	22	40	0,3-5,0	0,4-3,0
SW136-80	ONSNSW80-FM45-AM12-Z7-02	ON...12...	7	80	93	27	50	0,3-5,0	0,4-3,0
SW136-100	ONSNSW100-FM45-AM12-Z8-02	ON...12...	8	100	113	32	50	0,3-5,0	0,4-3,0
SW136-125	ONSNSW125-FM45-AM12-Z10-02	ON...12...	10	125	138	40	63	0,3-5,0	0,4-3,0
SW136-160	ONSNSW160-FM45-AM12-Z12-02	ON...12...	12	160	173	40	63	0,3-5,0	0,4-3,0

## ONSW...AM...

Aufsteckmesserkopf  
(Arbor Mounting)

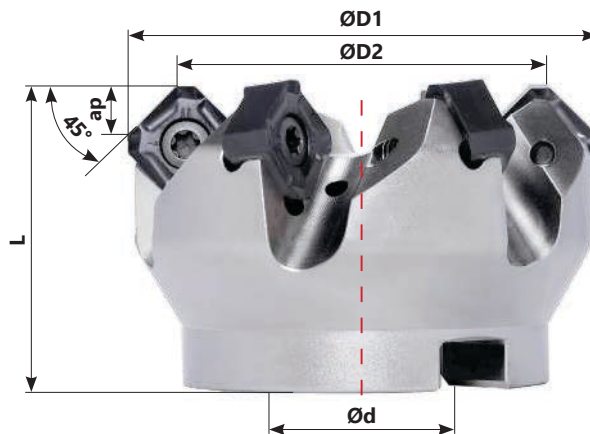

Bestellcode (Ordering Code)	Bezeichnung (Identification)	Platten (Inserts)		Maße (Dimensions) in mm					
		Typ (Type)	Anzahl (Number)	ØD1	ØD2	Ød	L	ap	
SW137-50	ONSNSW50-FM45-AM12-Z6-02	ON...12...	6	63	50	22	40	0,3-5,0	0,4-3,0
SW137-63	ONSNSW63-FM45-AM12-Z8-02	ON...12...	8	76	63	22	40	0,3-5,0	0,4-3,0
SW137-80	ONSNSW80-FM45-AM12-Z10-02	ON...12...	10	93	80	27	50	0,3-5,0	0,4-3,0
SW137-100	ONSNSW100-FM45-AM12-Z12-02	ON...12...	12	113	100	32	50	0,3-5,0	0,4-3,0
SW137-125	ONSNSW125-FM45-AM12-Z16-02	ON...12...	16	138	125	40	63	0,3-5,0	0,4-3,0



# SCHNITTDATEN (CUTTING DATA)

Zu bearbeitendes Material (Material to be machined)		HB	Verschleißfestigkeit (Wear Resistance)		Vc (m/min)		Zähigkeit (Toughness)
			SW11020	SW11030	SW11130	SW11140	SW00115
<b>P</b>	Unlegierter Stahl (Unalloyed Steel)	155-220	200-280	150-190	180-220	140-200	-
	Niedrig legierter Stahl (Low-Alloyed Steel)	220-280	170-220	140-170	140-210	120-180	-
	Hoch legierter Stahl (High-Alloyed Steel)	280-380	170-220	110-160	110-170	110-170	-
<b>M</b>	Rostfreier Stahl, ferritisch (Stainless Steels-Ferritic)	200-330	-	-	120-160	120-150	-
	Rostfreier Stahl, austenitisch (Stainless Steel-Austenitic)	200-330	-	-	90-140	70-130	-
<b>K</b>	Temperguss (Malleable Cast Iron)	130-230	190-270	-	140-200	160-200	-
	Grauguss (Grey Cast Iron)	180-245	190-240	-	130-170	130-180	-
	Gusseisen mit Kugelgraphit (Spheroidal Cast Iron)	160-250	160-220	-	120-160	120-170	-
<b>N</b>	Aluminium und NE-Metalle (Aluminium and Non Ferrous)	30-130	-	-	-	-	200-350
<b>Vorschub/Zahn (feed/tooth) in mm</b>		-	0,5-0,25	0,1-0,3	0,05-0,25	0,05-0,25	0,08-0,35

Alle Schnittdaten dienen zur Orientierung  
(All cutting datas serve to orientation)

# ZUBEHÖR FÜR SW136-137 (EQUIPMENT FOR SW136-137)

## ERSATZTEILE (SPARE PARTS)

Werkzeughdurchmesser (Tool Diameter) ØDc	Spannschraube (Insert Screw)	Torx Schlüssel (Torx Key)	Unterlegplatte / Unterlegscheibe (Shim / Washer)	Klemmschraube (Screw Clamp)
ONSW...AM...	SW5408795	BT20	-	-
-	-	-	-	-

# PLANFRÄSEN 45° SW100-102 (FACE MILLING 45° SW100-102)

## SESW...AM12...

Aufsteckmesserkopf  
(Arbor Mounting)

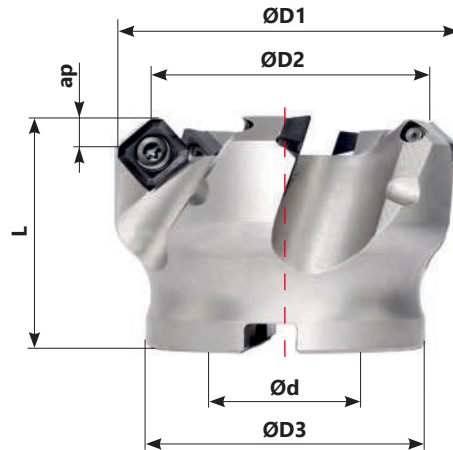

Bestellcode (Ordering Code)	Bezeichnung (Identification)	Platten (Inserts)		Maße (Dimensions) in mm					
		Typ (Type)	Anzahl (Number)	ØD1	ØD2	ØD3	Ød	L	ap
SW100-50	SESW50-FM45-AM12-Z4-03	SE...1204...	4	62	50	42	22	40	0,1-6,0
SW100-63	SESW63-FM45-AM12-Z5-03	SE...1204...	5	75	63	42	22	50	0,1-6,0
SW100-80	SESW80-FM45-AM12-Z6-03	SE...1204...	6	92	80	50	27	50	0,1-6,0
SW100-100	SESW100-FM45-AM12-Z6-03	SE...1204...	6	112	100	64	32	50	0,1-6,0

## PDSW...AM12...

Aufsteckmesserkopf  
(Arbor Mounting)

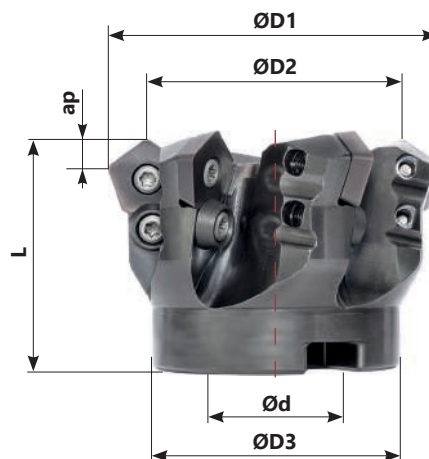

Bestellcode (Ordering Code)	Bezeichnung (Identification)	Platten (Inserts)		Maße (Dimensions) in mm					
		Typ (Type)	Anzahl (Number)	ØD1	ØD2	ØD3	Ød	L	ap
SW102-66	PDSW66-FM45-AM12-Z5-03	PD...1204...	5	66	47,5	48	27	55	0,2-5,5
SW102-80	PDSW80-FM45-AM12-Z6-03	PD...1204...	6	80	61,5	60	27	55	0,2-5,5
SW102-100	PDSW100-FM45-AM12-Z7-03	PD...1204...	7	100	81,5	70	32	55	0,2-5,5

# PLANFRÄSEN 45° SW100-102 (FACE MILLING 45° SW100-102)

## SESW...AM13...

### Aufsteckmesserkopf (Arbor Mounting)

**Anwendung mit einer Wiper-Platte:**  
Montieren Sie einen Plattensitz mit einer Wiper-Platte und die restlichen Plattensitze mit den Standard-Platten.

**Application with an Wiper-Insert:**  
Mount one Wiper Insert into the pocket and mount the remaining pockets with Standard-Inserts.

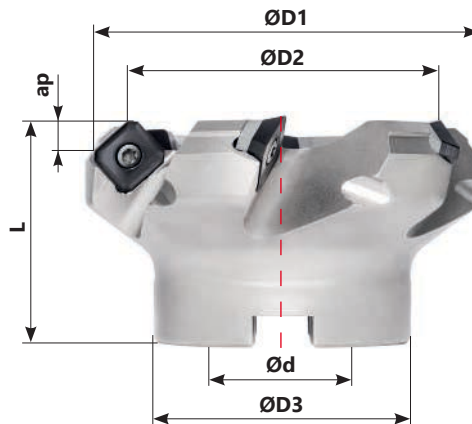

Bestellcode (Ordering Code)	Bezeichnung (Identification)	Platten (Inserts)		Maße (Dimensions) in mm					
		Typ (Type)	Anzahl (Number)	ØD1	ØD2	ØD3	Ød	L	ap
SW101-50	SESW50-FM45-AM13-Z4-03	SE...13T3...	4	63	50	40	22	40	0,2-6,0
SW101-63	SESW63-FM45-AM13-Z5-03	SE...13T3...	5	76	63	48	22	40	0,2-6,0
SW101-80	SESW80-FM45-AM13-Z6-03	SE...13T3...	6	93	80	60	27	50	0,2-6,0
SW101-100	SESW100-FM45-AM13-Z7-03	SE...13T3...	7	113	100	70	32	50	0,2-6,0
SW101-125	SESW125-FM45-AM13-Z8-03	SE...13T3...	8	138	125	90	40	63	0,2-6,0

### Empfohlene Schnittdaten (Recommended Cutting Conditions)

- Erhöhen Sie den Vorschub bei Verwendung einer Wiper-Platte um mindestens 40%, da die Wiper-Platte eine größere Schnittfläche hat, ist ein höherer Vorschub als bei Standardplatten notwendig.

*(Increase the feedrate when using an wiper insert by at least 40%, because the wiper insert has a larger cutting area as the standard insert and therefore a higher feedrate is necessary.)*

- Die empfohlene axiale Zustelltiefe beträgt 0,5mm bis 0,8mm.  
*(The recommended axial depth of cut is 0,5mm - 0,8mm.)*

! Berücksichtigen Sie in Ihren Berechnungen immer auch die Leistung Ihrer Maschine. !  
*! (Always consider the performance of your machine in your calculations.) !*

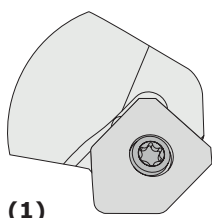

(1)

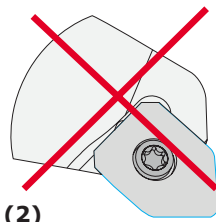

(2)

SEHT / SEHW / SEHT-LN

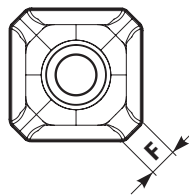

SEHT - W

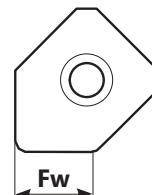

Setzen Sie die Wiper-Platte wie in Abbildung (1) ein.  
*(When using an wiper insert, install as shown on (1).)*

# FRÄSPLATTEN (MILLING INSERTS)

## SE...

Bestellcode (Ordering Code)	Qualität (Grades)											
	P					M		K			N	S
	PVD					PVD		PVD			UNC	PVD
	SW11910	SW11920	SW11740	SW11125	SW11135	SW11920	SW11740	SW11910	SW11920	SW11740	SW00910	SW11740



SEHT 1204 AFEN



SEHT 1204 AFTN



SEHT 1204 AFFN-LN



SEHW 1204 AFEN



SEHW 1204 AFTN



SEHT 13T3 AGSN



SEHT 13T3 AGFN-LN



SEHT 13T3 AGSN-W



SEHW 13T3 AGFN



## PD...



PDMW 120420 T



PDHW 120420 T



# SCHNITTDATEN (CUTTING DATA)

## SE...

Zu bearbeitendes Material (Material to be machined)		HB	Verschleißfestigkeit Zähigkeit (Wear Resistance) (Toughness)			Vorschub/Zahn (feed/tooth) in mm						
			Vc (m/min)			SEHT 1204...	SEHT 1204 LN	SEHW 1204...	SEHT 13T3 AGSN	SEHW 13T3 AGFN	SEHT 13T3 AGTN-LN	SEHT 13T3 AGSN-W
			SW11920	SW11740	SW00910							
<b>P</b>	Unlegierter Stahl (Unalloyed Steel)	125-220	150-230	130-160	-	0,10-0,20	-	0,10-0,20	0,10-0,25	-	-	0,10-0,30
	Niedrig legierter Stahl (Low-Alloyed Steel)	220-280	140-220	120-150	-	0,10-0,20	-	0,10-0,20	0,10-0,20	-	-	0,10-0,30
	Hoch legierter Stahl (High-Alloyed Steel)	280-380	130-180	100-130	-	0,10-0,20	-	0,10-0,20	0,10-0,20	-	-	0,10-0,30
<b>M</b>	Rostfreier Stahl, ferritisch (Stainless Steels-Ferritic)	200-330	-	100-120	-	0,10-0,15	-	0,10-0,20	0,10-0,20	-	-	-
	Rostfreier Stahl, austenitisch (Stainless Steel-Austenitic)	200-330	-	80-110	-	0,10-0,15	-	0,10-0,20	0,10-0,20	-	-	-
<b>K</b>	Temperguss (Malleable Cast Iron)	130-230	150-280	130-250	-	0,10-0,25	-	0,10-0,25	0,10-0,25	0,10-0,25	-	0,10-0,30
	Grauguss (Grey Cast Iron)	180-245	130-230	110-220	-	0,10-0,25	-	0,10-0,25	0,10-0,25	0,10-0,25	-	0,10-0,30
	Gusseisen mit Kugelgraphit (Spheroidal Cast Iron)	160-250	80-190	80-170	-	0,10-0,25	-	0,10-0,25	0,10-0,20	0,10-0,20	-	0,10-0,30
<b>N</b>	Aluminium und NE-Metalle (Aluminium and Non Ferrous)	30-130	-	-	350-1400	-	0,10-0,25	-	-	-	0,10-0,20	-

## PD...

Zu bearbeitendes Material (Material to be machined)		HB	Verschleißfestigkeit Vc (m/min)		Zähigkeit	Vorschub/Zahn (feed/tooth) in mm
					(Toughness)	
			SW11920	SW11125	SW11135	PDHW / PDMW
<b>P</b>	Unlegierter Stahl (Unalloyed Steel)	125-220	150-230	160-190	150-180	0,25-0,50
	Niedrig legierter Stahl (Low-Alloyed Steel)	220-280	140-220	140-180	140-170	0,25-0,50
	Hoch legierter Stahl (High-Alloyed Steel)	280-380	130-180	130-160	120-150	0,25-0,40
<b>K</b>	Temperguss (Malleable Cast Iron)	130-230	150-280	-	-	0,25-0,60
	Grauguss (Grey Cast Iron)	180-245	130-230	-	-	0,25-0,60
	Gusseisen mit Kugelgraphit (Spheroidal Cast Iron)	160-250	80-190	-	-	0,25-0,60

# SCHRÄGEINTAUCHEN UND HELIXINTERPOLATION (RAMPING AND HELICAL INTERPOLATION)

## PLATTEN - TECHNISCHE DATEN (INSERTS - TECHNICAL DETAILS)

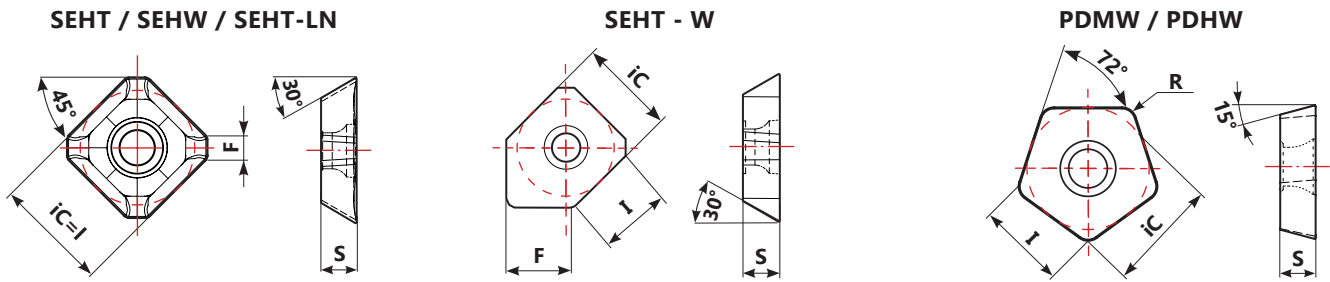

Bestellcode (Ordering Code)	Maße (Dimensions) in mm				
	ic	S	I	F	R
SEH...12...	12,70	4,76	12,70	2,80	-
SEHT 1204 AFFN-LN	12,70	4,76	12,70	2,00	-
SEH...13...	13,35	3,97	10,0	2,0	-
SEHT 13T3 AGFN-LN	13,35	3,97	10,0	2,3	-
SEHT 13T3 AGSN-W	13,35	3,97	10,0	8,2	-
PD...12...T	16,52	4,76	12,0	-	2,0



## SCHRÄGEINTAUCHEN UND HELIXINTERPOLATION (RAMPING & HELICAL INTERPOLATION)

Helixinterpolation (Helical Interpolation)				Schrägeintauchen (Ramping)	
<p>Sackloch; sauberer Grund (Blind hole; Flat bottom)</p>					
ØDc	ØDHmin	ØDHmax	Max Pitch/Rev.	Max Ramp $\alpha^\circ$	Max ap
66	113,3	130,4	28,4	8	5,5
80	141,3	158,4	25,9	6	5,5
100	181,3	198,4	23,2	4,3	5,5
125	231,3	248,4	21,7	3,2	5,5
160	301,3	318,4	20,8	2,4	5,5

Während der Helixinterpolation oder des Schrägeintauchens darf der maximale Steigungswinkel  $\alpha^\circ$  nicht überschritten werden  
(During helical interpolation or ramping do not exceed max Pitch  $\alpha^\circ$ )

# ZUBEHÖR FÜR SW100-102 (EQUIPMENT FOR SW100-102)

## ERSATZTEILE (SPARE PARTS)

Werkzeughdurchmesser (Tool Diameter) ØDc	Spannschraube (Insert Screw)	Torx Schlüssel (Torx Key)	Unterlegplatte / Unterlegscheibe (Shim / Washer)	Klemmschraube (Screw Clamp)
				
SESW...AM12...Ø50-Ø160	SW5001100	PT20	-	-
SESW...AM13...Ø50-Ø80	SW5051200	XT15	SW1303004	SW2503509
SESW...AM13...Ø100-Ø125	SW5051200	PT15	SW1303004	SW2503509
PDSW...AM12...Ø66-Ø80	SW5051001	XT20	SW3701200	SW5051001
PDSW...AM12...Ø100	SW5051001	PT20	SW3701200	SW5051001

# PLANFRÄSEN 45° SW120 (FACE MILLING 45° SW120)

## HPSW...WS...

Weldonschaft  
(Weldon Shank)

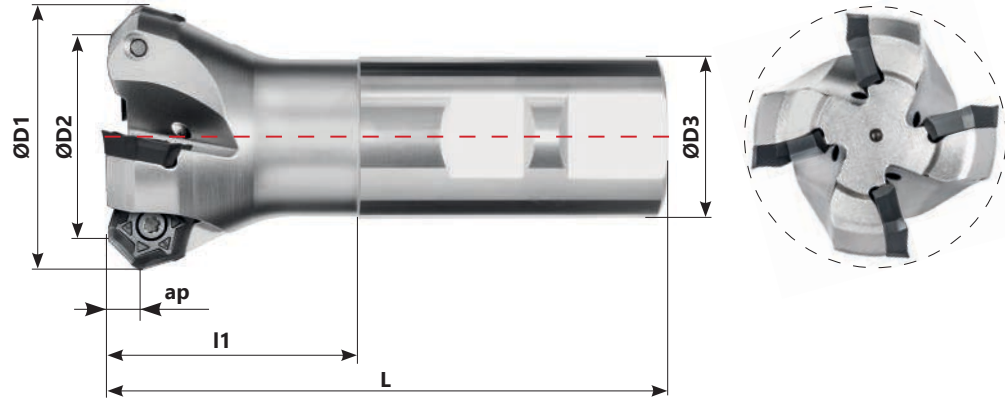
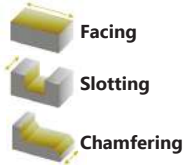

Bestellcode (Ordering Code)	Bezeichnung (Identification)	Platten (Inserts)		Maße (Dimensions) in mm					
		Typ (Type)	Anzahl (Number)	ØD1	ØD2	ØD3	L	l1	ap
SW120-40-1	HPSW40-FM45-WS06-Z4-01	HP...06...	4	52,2	40	32	110	50	0,2-4,0

## HPSW...AM...

Aufsteckmesserkopf  
(Arbor Mounting)

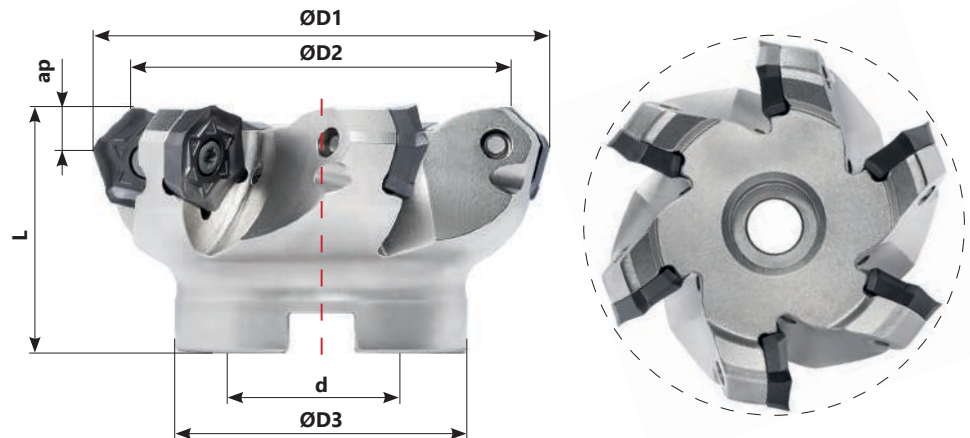
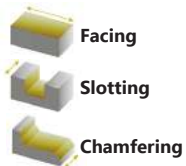

Bestellcode (Ordering Code)	Bezeichnung (Identification)	Platten (Inserts)		Maße (Dimensions) in mm					
		Typ (Type)	Anzahl (Number)	ØD1	ØD2	ØD3	Ød	L	ap
SW120-40-2	HPSW40-FM45-AM06-Z4-01	HP...06...	4	52,2	40	38	16	40	0,2-4,0
SW120-50	HPSW50-FM45-AM06-Z5-01	HP...06...	5	62,2	50	43	22	40	0,2-4,0
SW120-63	HPSW63-FM45-AM06-Z6-01	HP...06...	6	75,2	63	48	22	40	0,2-4,0
SW120-80	HPSW80-FM45-AM06-Z7-01	HP...06...	7	92,2	80	58	27	50	0,2-4,0
SW120-100	HPSW100-FM45-AM06-Z9-01	HP...06...	9	112,2	100	78	32	50	0,2-4,0
SW120-125	HPSW125-FM45-AM06-Z10-01	HP...06...	10	137,2	125	88	40	63	0,2-4,0

# FRÄSPLATTEN (MILLING INSERTS)

Bestellcode (Ordering Code)	Qualität (Grades)									
	P		M		K		N	S	H	
	CVD		PVD		PVD		UNC	PVD	PVD	
	SW22230	SW22535	SW11245	SW11235	.	.	.	SW00915	.	.



HPKT 0604AZER-HCM	▲	▲								
-------------------	---	---	--	--	--	--	--	--	--	--



HPKT 0604AZER-SCM			▲	▲						
-------------------	--	--	---	---	--	--	--	--	--	--



HPCT 0604AZFR-LMM							▲			
-------------------	--	--	--	--	--	--	---	--	--	--



HOKT 0604AZER-HCM	▲	▲								
-------------------	---	---	--	--	--	--	--	--	--	--



HOCT 0604AZER-SCM			▲	▲						
-------------------	--	--	---	---	--	--	--	--	--	--

## PLATTEN - TECHNISCHE DATEN (INSERTS - TECHNICAL DETAILS)

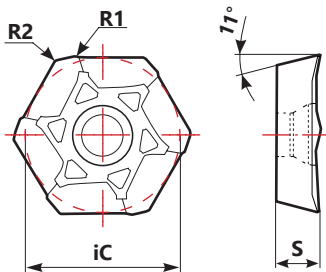

Bestellcode (Ordering Code)	Maße (Dimensions) in mm				
	iC	S	R1	R2	B
HP...0604...	16,3	4,5	0,4	0,5	-

# SCHNITTDATEN (CUTTING DATA)

Zu bearbeitendes Material (Material to be machined)		HB	Vorschubfestigkeit (Wear Resistance)						Zähigkeit (Toughness)		Vorschub/Zahn (feed/tooth) in mm
			Vc (m/min)								
			SW22230	SW11235	SW11245	SW22535	SW22415	SW00915			
<b>P</b>	Unlegierter Stahl (Unalloyed Steel)	155-220	110-280	100-240	-	150-260	-	-	0,1-0,37		
	Niedrig legierter Stahl (Low-Alloyed Steel)	220-280	100-250	90-220	-	80-220	-	-			
	Hoch legierter Stahl (High-Alloyed Steel)	280-380	60-130	60-110	-	90-180	-	-			
<b>M</b>	Rostfreier Stahl, ferritisch (Stainless Steels-Ferritic)	200-330	-	110-150	110-160	220-350	-	-	0,1-0,25		
	Rostfreier Stahl, austenitisch (Stainless Steel-Austenitic)	200-330	-	110-150	110-170	150-240	-	-			
<b>K</b>	Temperguss (Malleable Cast Iron)	130-230	100-190	-	-	-	200-320	120 - 200	0,05-0,33		
	Grauguss (Grey Cast Iron)	180-245	100-310	-	-	-	100 - 190	90 - 160			
	Gusseisen mit Kugelgraphit (Spheroidal Cast Iron)	160-250	90-200	-	-	-	100 - 180	90 - 170			
<b>N</b>	Aluminium und NE-Metalle (Aluminium and Non Ferrous)	30-130	-	-	-	-	-	60 - 1500	0,05-0,35		
<b>S</b>	Heat Resistant Super Alloys (Heat Resistant Super Alloys)	200-320	-	-	-	25-75	-	-	0,05-0,13		

Alle Schnittdaten dienen zur Orientierung  
(All cutting datas serve to orientation)

# ZUBEHÖR FÜR SW120 (EQUIPMENT FOR SW120)

## ERSATZTEILE (SPARE PARTS)

Werkzeigdurchmesser (Tool Diameter) ØDc	Spannschraube (Insert Screw)	Torx Schlüssel (Torx Key)	Unterlegplatte / Unterlegscheibe (Shim / Washer)	Klemmschraube (Screw Clamp)
HPSW...Ø52,2-Ø137,2	 SW5401115 M4,0 x 11	 T15	 -	 -
HPSW...AM...Ø52,2	SW5781826 M8,0 x 30,0	-	-	-

# PLANFRÄSEN 45° (FACE MILLING 45°)

## HNKU...AM08...

Aufsteckmesserkopf  
(Arbor Mounting)

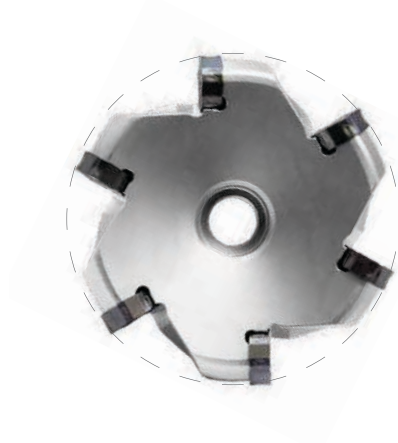
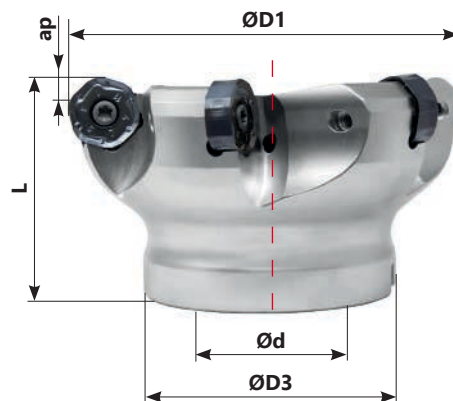
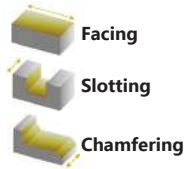

Bestellcode (Ordering Code)	Bezeichnung (Identification)	Platten (Inserts)		Maße (Dimensions) in mm				
		Typ (Type)	Anzahl (Number)	D1	D3	d	L	ap
SW141-40	HNSW40-FM-AM08-Z4-01	HN...08	4	40	38	16	40	0.2- 4.5
SW141-50	HNSW50-FM-AM08-Z4-01	HN...08	4	50	43	22	40	0.2- 4.5
SW141-63	HNSW63-FM-AM08-Z5-01	HN...08	5	63	48	22	40	0.2- 4.5
SW141-80	HNSW80-FM-AM08-Z6-01	HN...08	6	80	58	27	50	0.2- 4.5

# FRÄSPLATTEN (MILLING INSERTS)

Bestellcode (Ordering Code)	Qualität (Grades)									
	P		M		K			N	S	H
	CVD	PVD	PVD	CVD	PVD			UNC	-	PVD
	SW22230	SW11245	SW12240	SW22535	.	.	.	.	.	.



HNKU 0806AZER-HCM	▲	▲								
HNKU 0806AZER-SCM				▲						



HOKU 0806AZER-HCM	▲	▲								
HOKU 0806AZER-SCM			▲							
HOKU 0806AZER-SCM				▲						

## PLATTEN - TECHNISCHE DATEN (INSERTS - TECHNICAL DETAILS)

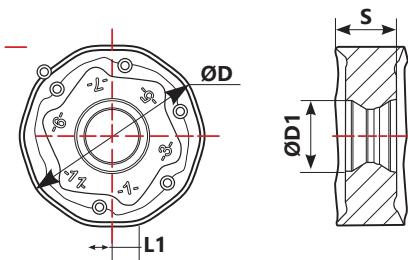

Bestellcode (Ordering Code)	Maße (Dimensions) in mm			
	D	S	L1	D1
HN... 08...	14.7	5.3	1.5	4.1
HO... 08...	14.7	5.3	1.5	4.1

# SCHNITTDATEN (CUTTING DATA)

Zu bearbeitendes Material (Material to be machined)	HB	Vc (m/min)						Vorschub/Zahn (feed/tooth) in mm
		Verschleißfestigkeit (Wear Resistance)			Zähigkeit (Toughness)			
		SW22230	SW11235	SW22535	SW12240	SW11245	-	
<b>P</b>	Unlegierter Stahl (Unalloyed Steel)	155-220	160-220	160-220	-	-	-	0,1-0,5
	Niedrig legierter Stahl (Low-Alloyed Steel)	220-280	100-200	100-200	-	-	-	
	Hoch legierter Stahl (High-Alloyed Steel)	280-380	60-120	60-120	-	-	-	
<b>M</b>	Rostfreier Stahl, ferritisch (Stainless Steels-Ferritic)	200-330	-	-	120-200	-	-	0,08-0,4
	Rostfreier Stahl, austenitisch (Stainless Steel-Austenitic)	200-330	-	-	60-160	-	-	

Alle Schnittdaten dienen zur Orientierung (All cutting datas serve to orientation)

## SCHNITTDATEN HNKU/HOKU (CUTTING DATA HNKU/HOKU)

Startparameter (Starting parameters)

$a_p$  [mm]

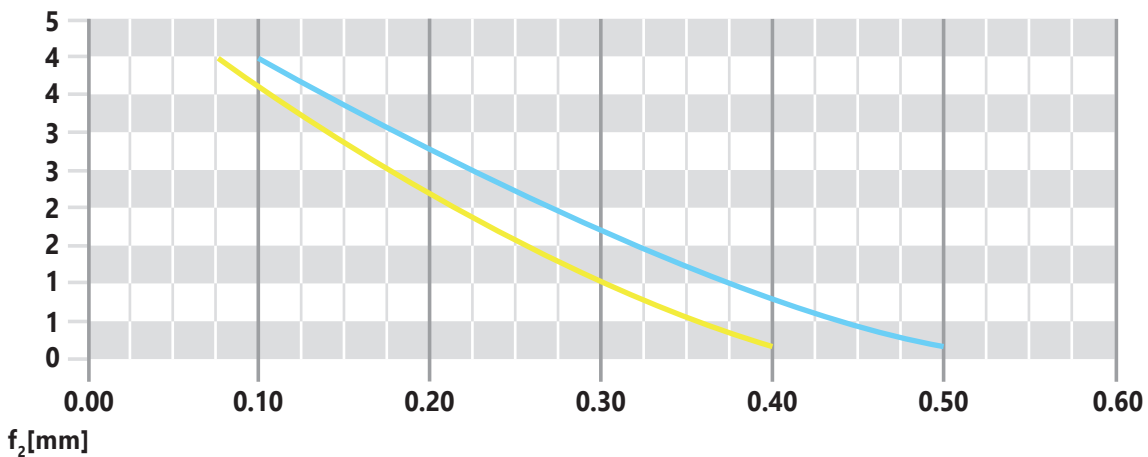

**ERSATZTEILE (SPARE PARTS)**

<b>Werkzeugdurchmesser</b> <i>(Tool Diameter)</i> <b>ØDc</b>	<b>Spannschraube</b> <i>(Insert Screw)</i>	<b>Torx Schlüssel</b> <i>(Torx Key)</i>	<b>Unterlegplatte / Unterlegscheibe</b> <i>(Shim / Washer)</i>	<b>Klemmschraube</b> <i>(Screw Clamp)</i>
<b>HNSW...</b>	 SW1345432	 T15	 -	 -

# PLANFRÄSEN 45° (FACE MILLING 45°)

## SOSW

**Aufsteckmesserkopf**  
(Arbor Mounting)

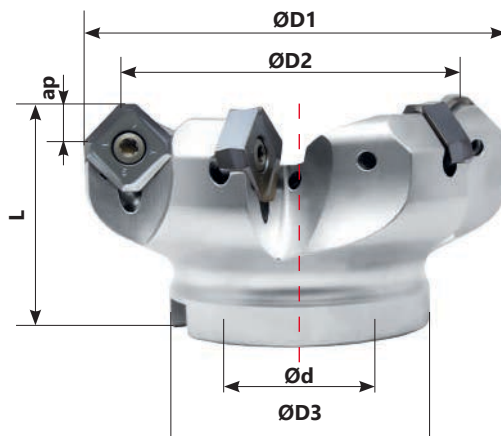
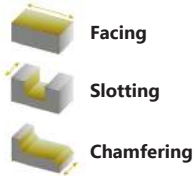

Bestellcode (Ordering Code)	Bezeichnung (Identification)	Platten (Inserts)		Maße (Dimensions) in mm				
		Typ (Type)	Anzahl (Number)	D1	D2	d	L	ap
SW151-40	SOSW40-FM-AM12-Z4-01	SO... 12...	4	52,4	40	16	45	0,2 - 6,0
SW151-50	SOSW50-FM-AM12-Z5-01	SO... 12...	5	62,4	50	22	45	0,2 - 6,0
SW151-63	SOSW63-FM-AM12-Z6-01	SO... 12...	6	75,4	63	22	45	0,2 - 6,0
SW151-80	SOSW80-FM-AM12-Z8-01	SO... 12...	8	92,4	80	27	50	0,2 - 6,0
SW151-100	SOSW100-FM-AM12-Z10-01	SO... 12...	10	112,4	100	32	50	0,2 - 6,0
SW151-125	SOSW125-FM-AM12-Z12-01	SO... 12...	12	137,4	125	40	63	0,2 - 6,0

## SOSW

**Aufsteckmesserkopf**  
(Arbor Mounting)

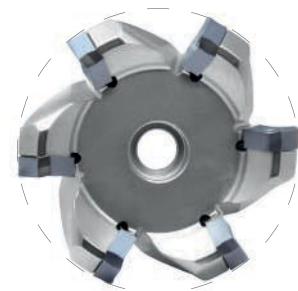
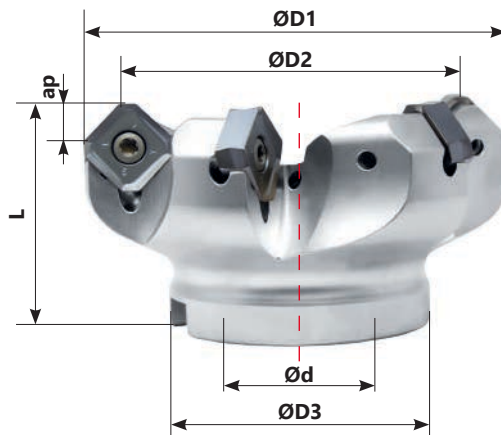
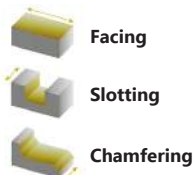

Bestellcode (Ordering Code)	Bezeichnung (Identification)	Platten (Inserts)		Maße (Dimensions) in mm					
		Typ (Type)	Anzahl (Number)	D1	D2	D3	d	L	ap
SW152-40	SOSW40-FM-AM15-Z4-01	SO... 15...	4	55	40	38	16	45	0,2 - 6,5
SW152-50	SOSW50-FM-AM15-Z4-01	SO... 15...	4	65	50	43	22	45	0,2 - 6,5
SW152-63	SOSW63-FM-AM15-Z5-01	SO... 15...	5	78	63	48	22	45	0,2 - 6,5
SW152-80	SOSW80-FM-AM15-Z6-01	SO... 15...	6	95	80	58	27	50	0,2 - 6,5
SW152-100	SOSW100-FM-AM15-Z7-01	SO... 15...	7	115	100	78	32	50	0,2 - 6,5
SW152-125	SOSW125-FM-AM15-Z8-01	SO... 15...	8	140	125	88	40	63	0,2 - 6,5
SW152-160	SOSW160-FM-AM15-Z10-01	SO... 15...	10	175	160	93,4	40	63	0,2 - 6,5

# FRÄSPLATTEN (MILLING INSERTS)

Bestellcode (Ordering Code)	Qualität (Grades)										
	P			M		K		N	S		H
	CVD		PVD	PVD	CVD	CVD	PVD	UNC	CVD		PVD
	SW22230	SW22535	SW11235	SW11245	SW22535	SW22415	SW12220	SW00915	SW22535	SW22540	SW12115



SOKU 1205AZER-HCM	▲	▲	▲								
SOKU 1205AZER-SCM				▲	▲						



SOKU 1505AZER-HCM	▲	▲	▲								
SOKU 1505AZER-SCM				▲	▲						
SOKU 1505AZER-CCM						▲	▲				

## PLATTEN - TECHNISCHE DATEN (INSERTS - TECHNICAL DETAILS)

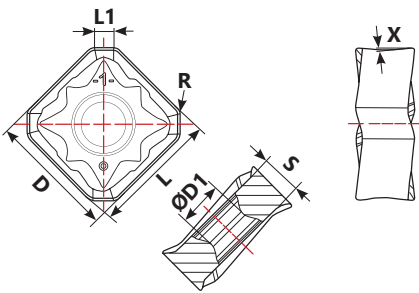

Bestellcode (Ordering Code)	Maße (Dimensions) in mm						
	D	D1	S	L	L1	R	x
SO... 12...	13	4.55	5	13	2	0.8	6
SO... 15...	15.875	5.74	6.0	15.875	2.7	1.0	6

# SCHNITTDATEN (CUTTING DATA)

Zu bearbeitendes Material (Material to be machined)	HB	Verschleißfestigkeit (Wear Resistance)							Zähigkeit (Toughness)	Vorschub/Zahn (feed/tooth) in mm
		Vc (m/min)								
		SW22230	SW22235	SW11235	SW11245	SW22535	SW22415	SW22415		
<b>P</b> Unlegierter Stahl (Unalloyed Steel)	155-220	120-220	120-220	120-220	-	-	-	-	0,1-0,3	
	220-280	80-180	80-180	80-180	-	-	-	-		
	280-380	60-160	60-160	60-160	-	-	-	-		
<b>M</b>	Rostfreier Stahl, ferritisch (Stainless Steels-Ferritic)	200-330	-	-	-	100-200	100-200	-	-	0,08-0,2
	Rostfreier Stahl, austenitisch (Stainless Steel-Austenitic)	200-330	-	-	-	60-160	60-160	-	-	
<b>K</b>	Temperguss (Unalloyed Steel)	130-230	-	-	-	-	-	200- 320	200- 320	0,08-0,45
	Grauguss (Grey Cast Iron)	180-245	-	-	-	-	-	150- 280	150- 280	
	Gusseisen mit Kugelgraphit (Spheroidal Cast Iron)	160-250	-	-	-	-	-	100- 220	100- 220	

Alle Schnittdaten dienen zur Orientierung (All cutting datas serve to orientation)

## ERSATZTEILE (SPARE PARTS)

Werkzeigdurchmesser (Tool Diameter) ØDc	Spannschraube (Insert Screw)	Torx Schlüssel (Torx Key)	Unterlegplatte / Unterlegscheibe (Shim / Washer)	Klemmschraube (Screw Clamp)
AM...				
WS...	SW1345432	-	-	-
	SW11037484	-	-	-

**SCHNITTDATEN SDMX (CUTTING DATA SOKU12)**

---

Startparameter (Starting parameters)

$a_p$  [mm]

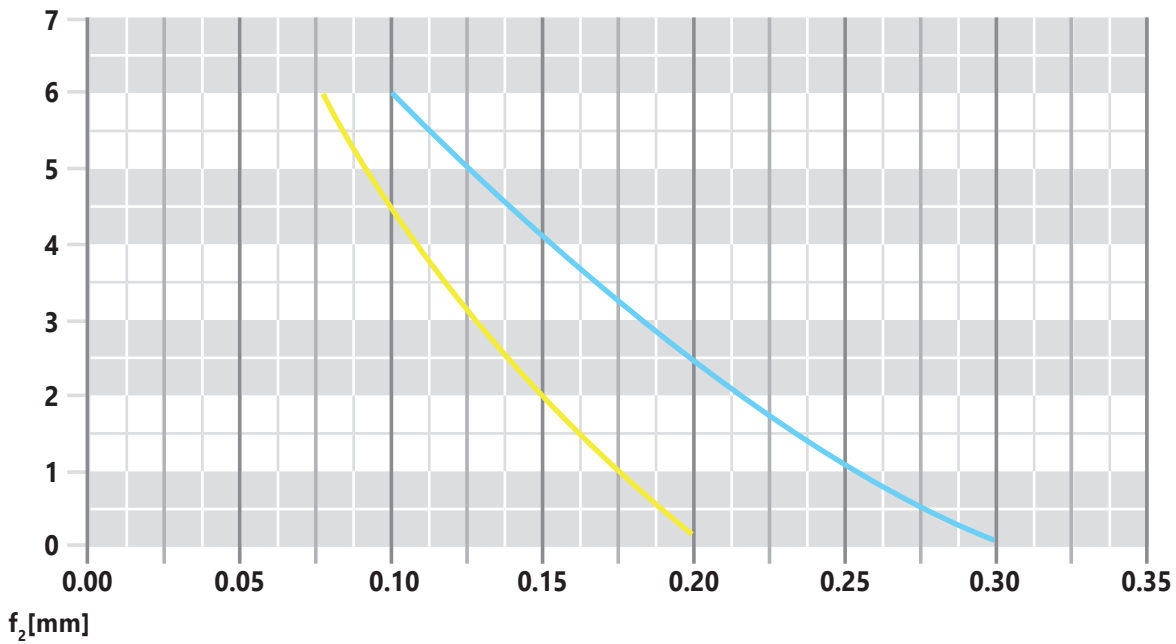

**SCHNITTDATEN SDMX (CUTTING DATA SOKU15)**

---

Startparameter (Starting parameters)

$a_p$  [mm]

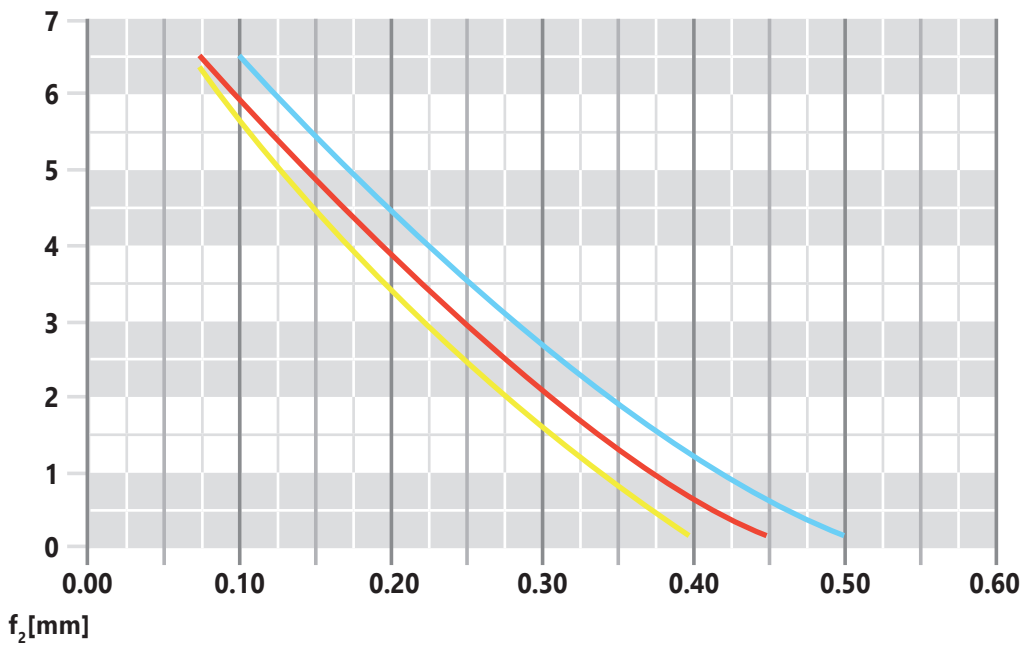



**PRODUKTBEZEICHNUNG (PRODUCT IDENTIFICATION)**

**BEISPIEL (EXAMPLE): RDSW 42-PFM-TC 12-Z6-01**

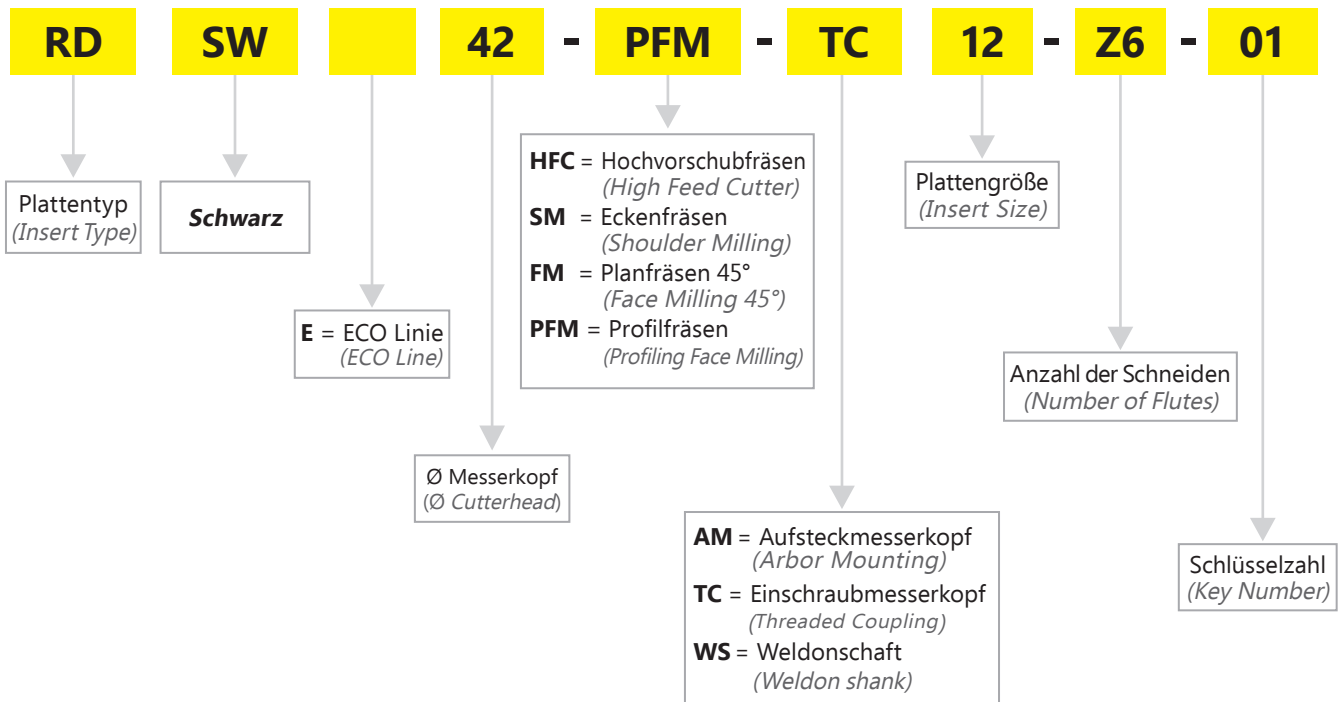

# FORCE LINE

PLANFRÄSEN / PROFILFRÄSEN  
(FACE MILLING / PROFILING)



## SDMX, EOMT, RPMX,

### Weldonschaft (Weldon Shank)

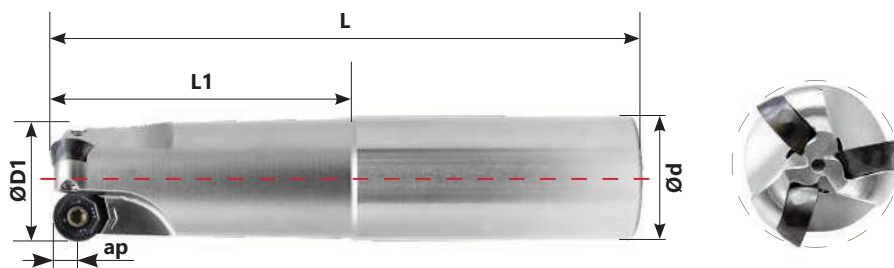
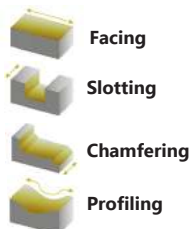

Bestellcode (Ordering Code)	Bezeichnung (Identification)	Platten (Inserts)		Maße (Dimensions) in mm				
		Typ (Type)	Anzahl (Number)	D1	d	L	L1	ap
SW153-25-1	SDRPEOSW25-PFM-WS11-Z2-01	SD... EO... RP...	2	25	25	86,3	30,3	0,1 - 5,5
SW153-25-2	SDRPEOSW25-PFM-WS11-Z2-01	SD... EO... RP...	2	25	25	116,3	60,3	0,1 - 5,5
SW153-32-1	SDRPEOSW32-PFM-WS11-Z3-01	SD... EO... RP...	3	32	32	100,3	40,3	0,1 - 5,5
SW153-32-2	SDRPEOSW32-PFM-WS11-Z3-01	SD... EO... RP...	3	32	32	70,3	70,3	0,1 - 5,5

## SDMX, EOMT, RPMX,



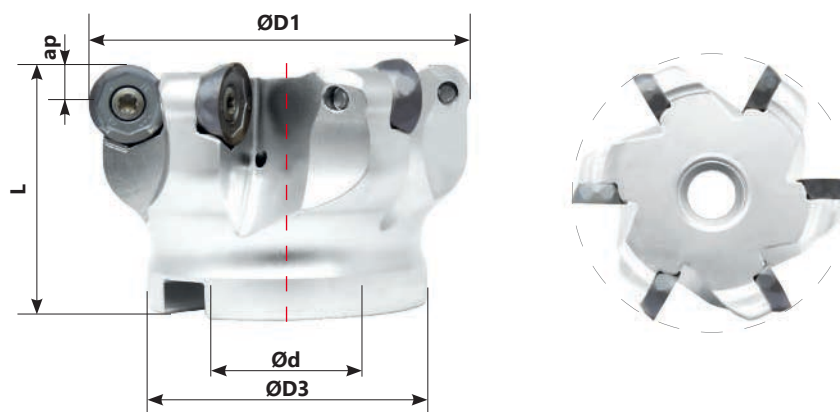
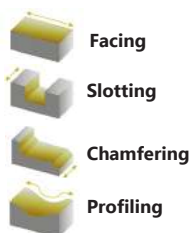

### Aufsteckmessenkopf (Arbor Mounting)



Bestellcode (Ordering Code)	Bezeichnung (Identification)	Platten (Inserts)		Maße (Dimensions) in mm				
		Typ (Type)	Anzahl (Number)	D1	D2	D3	L	ap
SW154-40	SDRPEOSW40-PFM-AM11-Z4-01	SD.EO.RP11/12	4	40	32,5	38	40,3	0,1 - 5,5
SW154-50	SDRPEOSW50-PFM-AM11-Z5-01	SD.EO.RP11/12	5	50	42,5	43	40,3	0,1 - 5,5
SW154-63	SDRPEOSW63-PFM-AM11-Z6-01	SD.EO.RP11/12	6	63	55,5	48	40,3	0,1 - 5,5
SW154-80	SDRPEOSW80-PFM-AM11-Z8-01	SD.EO.RP11/12	8	80	72,5	58	50,3	0,1 - 5,5
SW154-100	SDRPEOSW100-PFM-AM11-Z10-01	SD.EO.RP11/12	10	100	92,5	78	50,3	0,1 - 5,5

**SDMX, EOMT, RPMX,**

**Aufsteckmesserkopf**  
*(Arbor Mounting)*

-  Facing
-  Slotting
-  Chamfering
-  Profiling

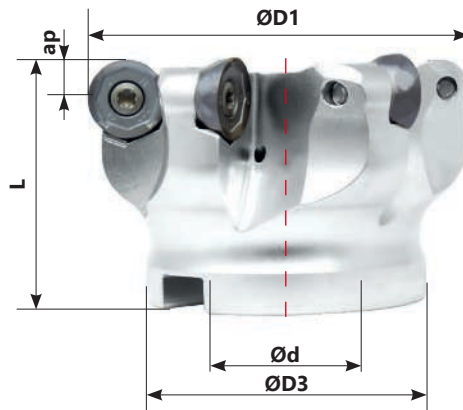

Bestellcode <i>(Ordering Code)</i>	Bezeichnung <i>(Identification)</i>	Platten <i>(Inserts)</i>		Maße <i>(Dimensions)</i> in mm				
		Typ <i>(Type)</i>	Anzahl <i>(Number)</i>	D1	D2	D3	L	ap
SW155-50	SDRPEOSW50-PFM-AM15-Z3-01	SD... EO... RP...	3	50	39,8	48	40,5	0,1 - 5,5
SW155-63	SDRPEOSW63-PFM-AM15-Z5-01	SD... EO... RP...	5	63	52,8	48	40,5	0,1 - 5,5
SW155-80	SDRPEOSW80-PFM-AM15-Z6-01	SD... EO... RP...	6	80	69,8	58	50,5	0,1 - 5,5
SW155-100	SDRPEOSW100-PFM-AM15-Z7-01	SD... EO... RP...	7	100	89,8	78	50,5	0,1 - 5,5
SW155-125	SDRPEOSW125-PFM-AM15-Z8-01	SD... EO... RP...	8	125	114,8	88	63,4	0,1 - 5,5

# FRÄSPLATTEN (MILLING INSERTS)

Bestellcode (Ordering Code)	Qualität (Grades)										
	P			M		K		N	S		H
	CVD	PVD		PVD	CVD	PVD		UNC	CVD		PVD
	SW22230	SW11235	.	SW11245	SW22535	.	.	SW00915	SW22535	SW22540	SW12115



EOMT 120416-HCM	▲	▲									
EOMT 120416-SCM				▲	▲						



RPMX 1204MO-MFHCM	▲	▲									
RPMX 1204MO-MFSCM				▲	▲						



RPMX 1605MO-MFHCM	▲	▲									
RPMX 1605MO-MFSCM				▲	▲						



SDMX 1105AEER-HCM	▲	▲									
SDMX 1105AEER-SCM				▲	▲						



SDMX 1506AEER-HCM	▲	▲									
SDMX 1506AEER-SCM				▲	▲						

**PLATTEN - TECHNISCHE DATEN** (*INSERTS - TECHNICAL DETAILS*)

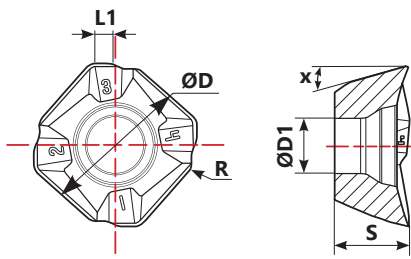

Bestellcode (Ordering Code)	Maße (Dimensions) in mm					
	D	D1	S	L1	R	x
SDMX... 11...	11.4	4.4	5.9	1.0	0.8	15
SDMX... 15...	15	5.5	6.5	1.5	0.8	15

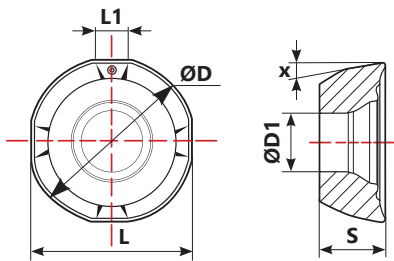

Bestellcode (Ordering Code)	Maße (Dimensions) in mm					
	D	D1	S	L	L1	X
RPMX... 12...	12	4.4	4.76	11.75	2.4	11
RPMX... 16...	16	5.5	5.56	15.8	2.5	11

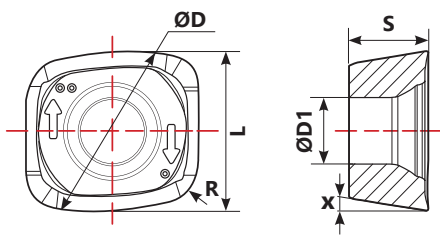

Bestellcode (Ordering Code)	Maße (Dimensions) in mm					
	D	D1	S	L	R	X
EOMT... 12...	12	4.4	5	10.5	16	9

# SCHNITTDATEN (CUTTING DATA)

Zu bearbeitendes Material (Material to be machined)		HB	Verschleißfestigkeit (Wear Resistance)				Zähigkeit (Toughness)				
			Vc (m/min)				Vorschub/Zahn (feed/tooth) in mm				
			SW22230	SW11235	SW11245	SW22535	SDMX11	SDMX15	R...12	R...16	EOMT12
<b>P</b>	Unlegierter Stahl (Unalloyed Steel)	155-220	120-220	120-220	-	-	0,1-0,4	0,1-0,5	0,12-0,45	0,25-0,8	0,1-2,5
	Niedrig legierter Stahl (Low-Alloyed Steel)	220-280	100-200	100-200	-	-					
	Hoch legierter Stahl (High-Alloyed Steel)	280-380	60-160	60-160	-	-					
<b>M</b>	Rostfreier Stahl, ferritisch (Stainless Steels-Ferritic)	200-330	-	-	100-200	100-200	0,08-0,35	0,08-0,4	0,1-0,4	0,2-0,6	0,08-1,5
	Rostfreier Stahl, austenitisch (Stainless Steel-Austenitic)	200-330	-	-	60-150	60-150					

Alle Schnittdaten dienen zur Orientierung (All cutting datas serve to orientation)

## SCHNITTDATEN SDMX... 11 (CUTTING DATA SDMX... 11)

Startparameter (Starting parameters)

$a_p$  [mm]

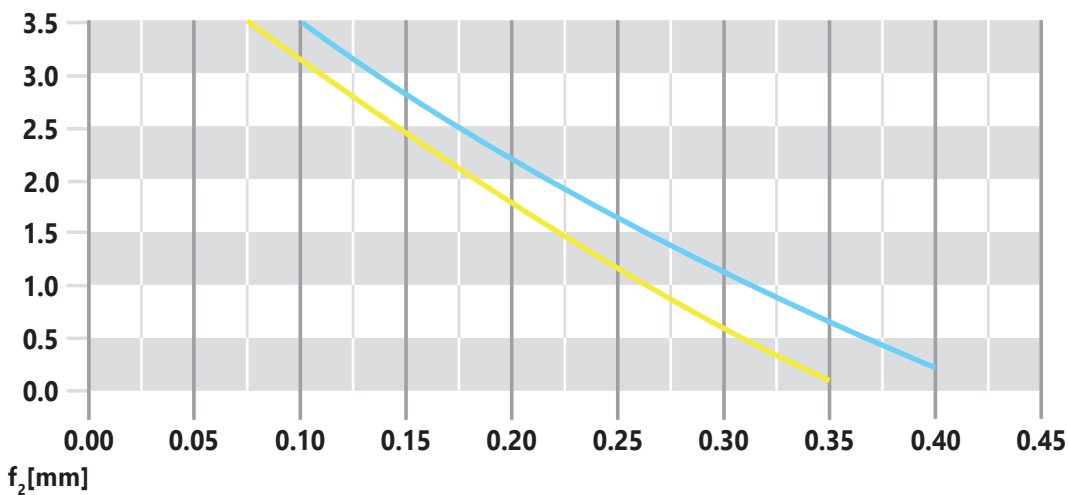

## SCHNITTDATEN RPMX... 15 (CUTTING DATA RPMX... 15)

Startparameter (Starting parameters)

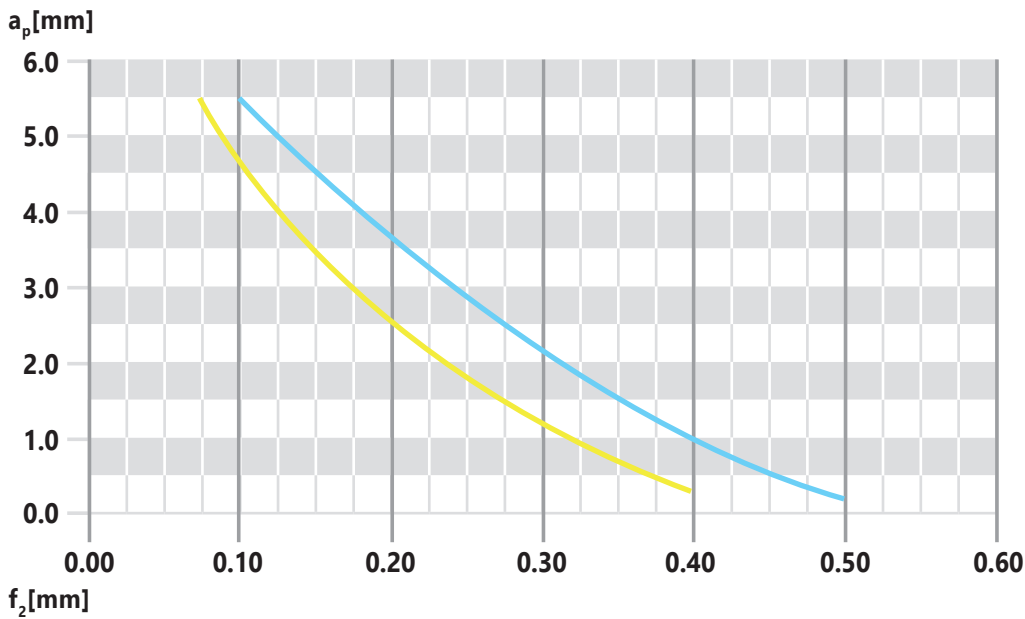

## SCHNITTDATEN RPMX... 12 (CUTTING DATA RPMX... 12)

Startparameter (Starting parameters)

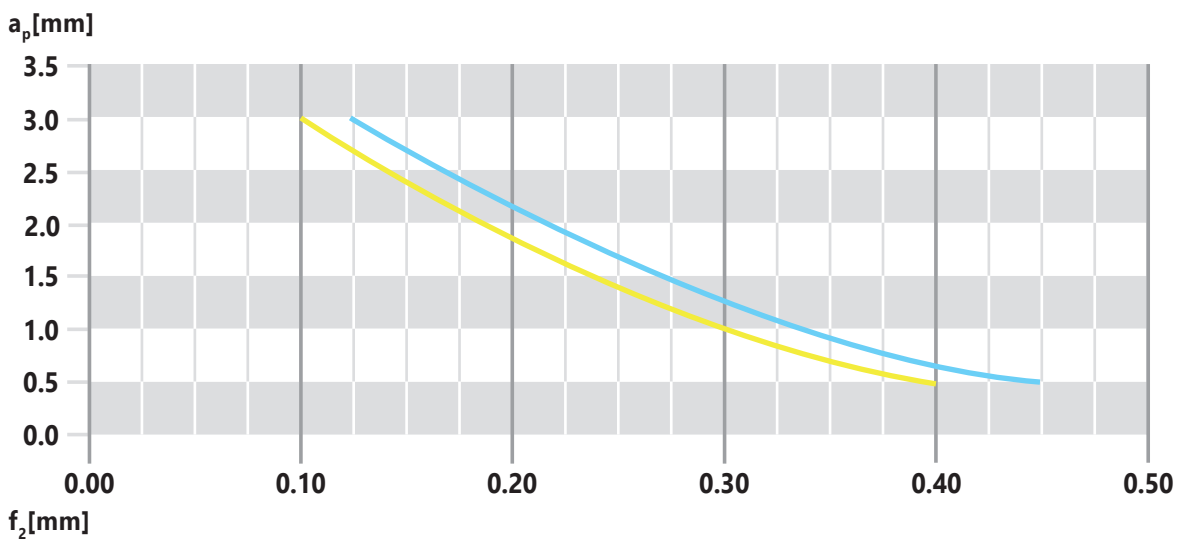

## EMPFOHLENE SCHNITTWERTE (RECOMMENDED PARAMETERS)

Ø	Indexing (4 times)	
	$a_p$	$a_p$ max
12	3.0	5.5
16	4.0	7.5

## SCHNITTDATEN RPMX... 16 (CUTTING DATA RPMX... 16)

Startparameter (Starting parameters)

$a_p$  [mm]

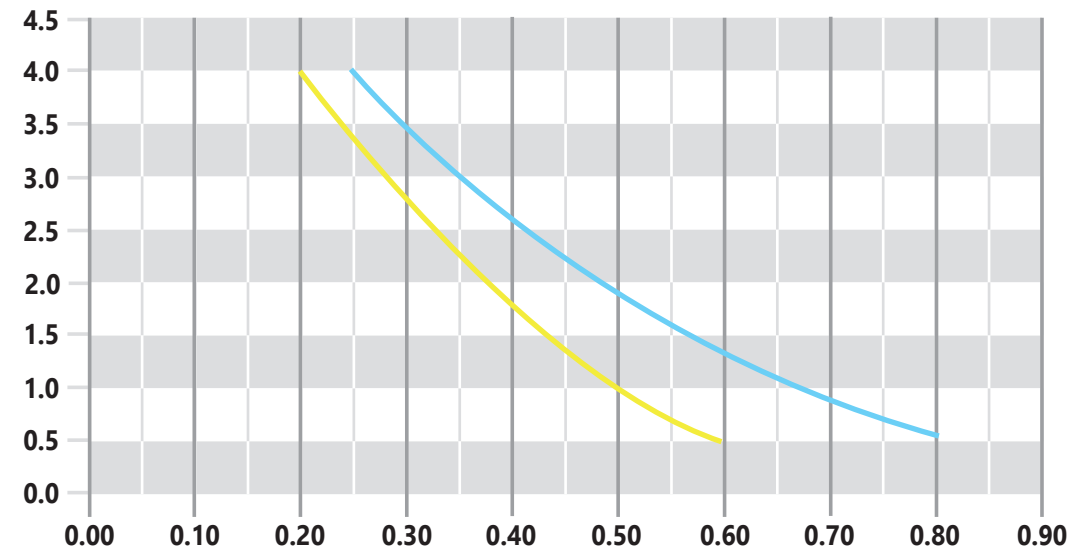

$f_2$  [mm]

## EMPFOHLENE SCHNITTWERTE (RECOMMENDED PARAMETERS)

Indexing (4 times)		
$\emptyset$	$a_p$	$a_p$ max
12	3.0	5.5
16	4.0	7.5

**SCHNITTDATEN EOMT (CUTTING DATA EOMT)**

Startparameter (Starting parameters)

$a_p$  [mm]

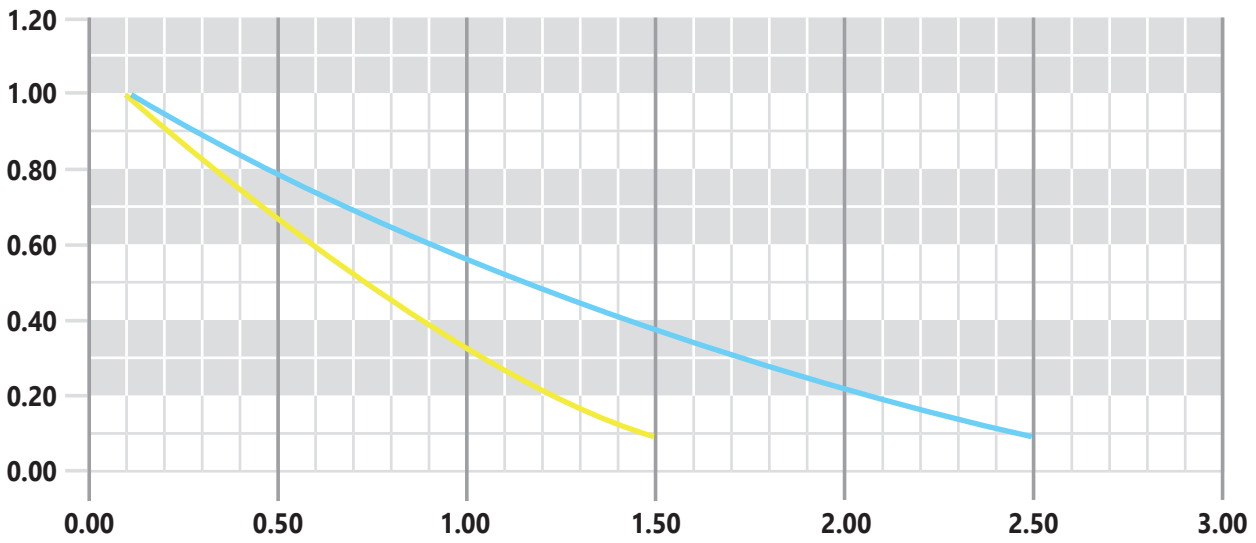

$f_2$  [mm]

**ERSATZTEILE (SPARE PARTS)**

Werkzeugdurchmesser (Tool Diameter) $\varnothing D_c$	Spannschraube (Insert Screw)	Torx Schlüssel (Torx Key)	Unterlegplatte / Unterlegscheibe (Shim / Washer)	Klemmschraube (Screw Clamp)
AM...	 SW1345432	 -	 -	 -
WS...	SW11037484	-	-	-
SDRPEOSW40-PFM-AM11-Z4-01	-	-	-	SW11036880

**XDSW...TC...**

Einschraubmesserkopf  
 (Threaded Coupling)

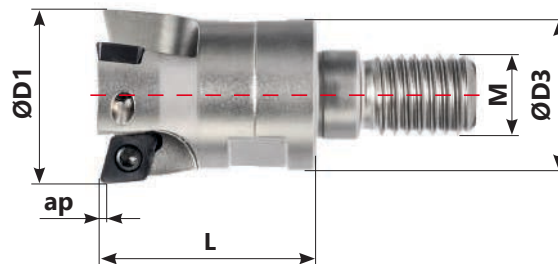

Bestellcode (Ordering Code)	Bezeichnung (Identification)	Platten (Inserts)		Maße (Dimensions) in mm				
		Typ (Type)	Anzahl (Number)	ØD1	ØD3	M	L	ap
SW103-10	XDSW10-PFM-TC04-Z2-03	XD...0401...	2	10	9,8	M6	20	0,1-0,8
SW103-12	XDSW12-PFM-TC04-Z2-03	XD...0401...	2	12	9,8	M6	20	0,1-0,8
SW103-16	XDSW16-PFM-TC06-Z2-03	XD...0602...	2	16	13	M8	23	0,1-1,0
SW103-20	XDSW20-PFM-TC06-Z3-03	XD...0602...	3	20	18	M10	28	0,1-1,0
SW103-25-1	XDSW25-PFM-TC06-Z3-03	XD...0602...	3	25	21	M12	30	0,1-1,0
SW103-25-2	XDSW25-PFM-TC06-Z4-03	XD...0602...	4	25	21	M12	30	0,1-1,0
SW103-25-3	XDSW25-PFM-TC10-Z2-03	XD...10T3...	2	25	21	M12	35	0,1-1,0
SW103-35	XDSW35-PFM-TC10-Z3-03	XD...10T3...	3	35	29	M16	43	0,1-1,0
SW103-42	XDSW42-PFM-TC10-Z4-03	XD...10T3...	4	42	29	M16	43	0,1-1,0

**XDSW...AM...**

Aufsteckmesserkopf  
 (Arbor Mounting)

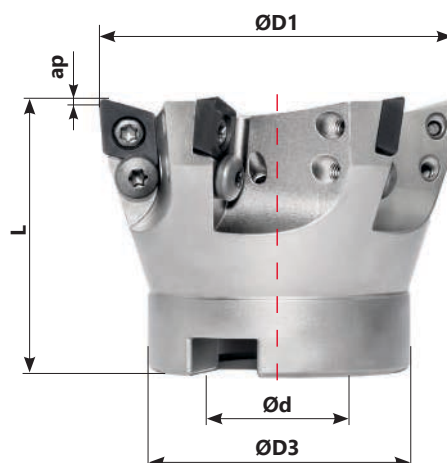

Bestellcode (Ordering Code)	Bezeichnung (Identification)	Platten (Inserts)		Maße (Dimensions) in mm				
		Typ (Type)	Anzahl (Number)	ØD1	ØD3	Ød	L	ap
SW104-52	XDSW52-PFM-AM10-Z5-03	XD...10T3...	5	52	40	22	50	0,1-1,0
SW104-66	XDSW66-PFM-AM10-Z6-03	XD...10T3...	6	66	48	27	50	0,1-1,0
SW104-80	XDSW80-PFM-AM10-Z7-03	XD...10T3...	7	80	60	27	50	0,1-1,0

# FRÄSPLATTEN (MILLING INSERTS)

Bestellcode (Ordering Code)	Qualität (Grades)										
	P				M	K			N	S	H
	PVD				PVD	PVD			UNC	PVD	PVD
	SW11103	SW11910	SW11125	SW11135	SW11920	SW11910	SW11920	SW11125	.	SW11740	SW11103



<b>XDHW 040110</b>	▲	▲	▲			▲		▲			▲
--------------------	---	---	---	--	--	---	--	---	--	--	---



<b>XDHW 060210</b>	▲	▲	▲	▲		▲		▲			▲
--------------------	---	---	---	---	--	---	--	---	--	--	---



<b>XDHW 10T310</b>	▲	▲	▲	▲		▲		▲			▲
--------------------	---	---	---	---	--	---	--	---	--	--	---

## PLATTEN - TECHNISCHE DATEN (INSERTS - TECHNICAL DETAILS)

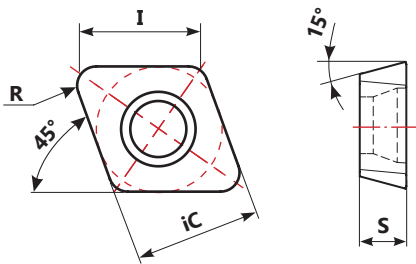

Bestellcode (Ordering Code)	Maße (Dimensions) in mm				
	iC	S	I	B	R
XDHW 040105	4,00	1,59	4,00	-	0,50
XDHW 040110	4,00	1,59	4,00	-	1,00
XDHW 060210	6,50	2,38	6,20	-	1,00
XDHW 10T310	10,00	3,97	9,90	-	1,00

# SCHNITTDATEN (CUTTING DATA)

	Zu bearbeitendes Material (Material to be machined)	HB	Vc (m/min)			
			Verschleißfestigkeit (Wear Resistance)			Zähigkeit (Toughness)
			SW11103	SW11910	SW11125	SW11135
<b>P</b>	Unlegierter Stahl (Unalloyed Steel)	125-220	180-300	180-250	160-190	150-180
	Niedrig legierter Stahl (Low-Alloyed Steel)	220-280	180-250	170-210	140-180	140-170
	Hoch legierter Stahl (High-Alloyed Steel)	280-380	180-230	160-200	130-160	120-150
<b>K</b>	Temperguss (Malleable Cast Iron)	130-230	-	170-300	160-290	-
	Grauguss (Grey Cast Iron)	180-245	-	150-250	140-240	-
	Gusseisen mit Kugelgraphit (Spheroidal Cast Iron)	160-250	-	90-210	80-200	-
<b>N</b>	Aluminium und NE-Metalle (Aluminium and Non Ferrous)	30-130	-	-	-	-
<b>H</b>	Gehärteter Stahl (Hardened Steel)	40-55 HRc	120-160	-	-	-

Platte (Insert)	Vorschub/Zahn (feed/tooth) in mm		ap Rec.
	Roughing	Finishing	
<b>XD...04...</b>	<b>0,10-0,20</b>	<b>0,10-0,15</b>	<b>0,1-0,5</b>
<b>XD...06...</b>	<b>0,15-0,30</b>	<b>0,10-0,25</b>	<b>0,2-0,8</b>
<b>XD...10...</b>	<b>0,15-0,35</b>	<b>0,10-0,30</b>	<b>0,2-0,8</b>

Alle Schnittdaten dienen zur Orientierung  
(All cutting datas serve to orientation)

# SCHRÄGEINTAUCHEN UND HELIXINTERPOLATION (RAMPING AND HELICAL INTERPOLATION)

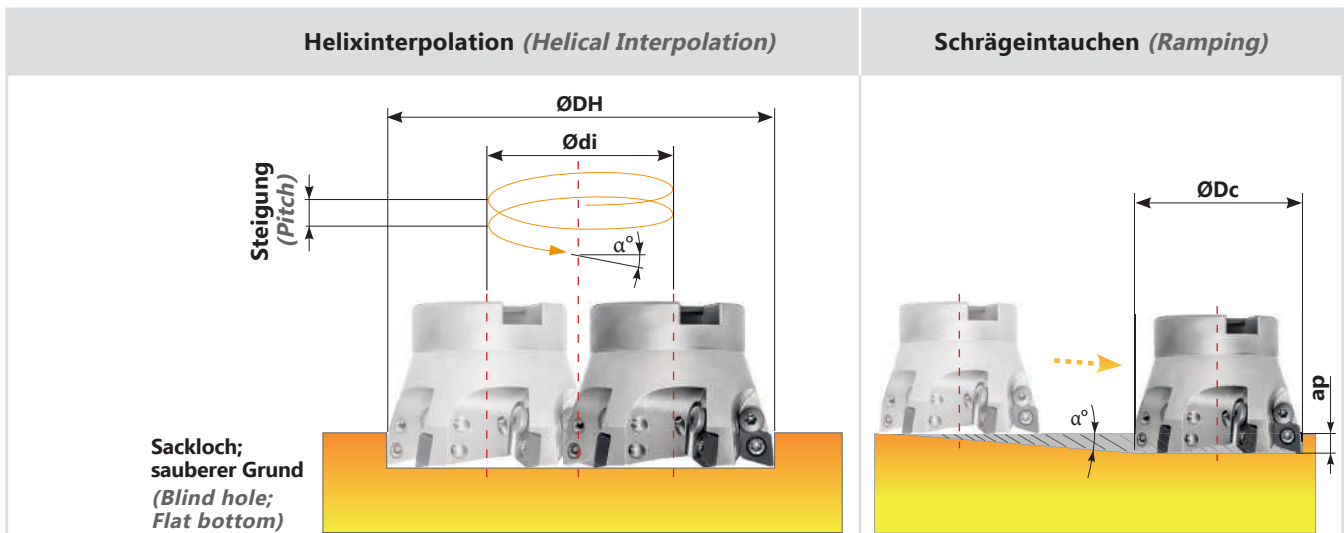

Platte (Insert)	ØDc	ØDHmin	ØDHmax	Max Pitch/Rev	Max Ramp $\alpha^\circ$	Max ap
XD...04...	10	18,0	20,0	4,0	7,3°	0,8
	12	22,0	24,0	3,5	5,3°	0,8
XD...06...	16	30,0	32,0	7,1	8°	1,0
	20	38,0	40,0	6,3	5,7°	1,0
	25	48,0	50,0	5,5	4°	1,0
XD...10...	25	48,0	50,0	12,0	8,7°	1,0
	35	68,0	70,0	10,0	5,2°	1,0
	42	82,0	84,0	9,2	4°	1,0
	52	102,0	104,0	8,6	3°	1,0
	66	130,0	132,0	8,3	2,3°	1,0
	80	158,0	160,0	7,9	1,8°	1,0

Während der Helixinterpolation oder des Schrägeintauchens darf der maximale Steigungswinkel  $\alpha^\circ$  nicht überschritten werden  
(During helical interpolation or ramping do not exceed max Pitch  $\alpha^\circ$ )

## ERSATZTEILE FÜR SW103-104 (SPARE PARTS FOR SW103-104)

Werkzeugdurchmesser (Tool Diameter) ØDc	Spannschraube (Insert Screw)	Torx Schlüssel (Torx Key)	Unterlegplatte / Unterlegscheibe (Shim / Washer)	Klemmschraube (Screw Clamp)
XDSW...TC...Ø10-Ø12	SW5180401	XT06	-	-
XDSW...TC...Ø16-Ø25	SW5250503	XT08	-	-
XDSW...TC...Ø25-Ø42	SW5350800	XT15	-	-
XDSW...TC...Ø52-Ø80	SW5350800	XT15	SW4350750	-

## RP...RD...

**Weldonschaft**  
(Weldon Shank)

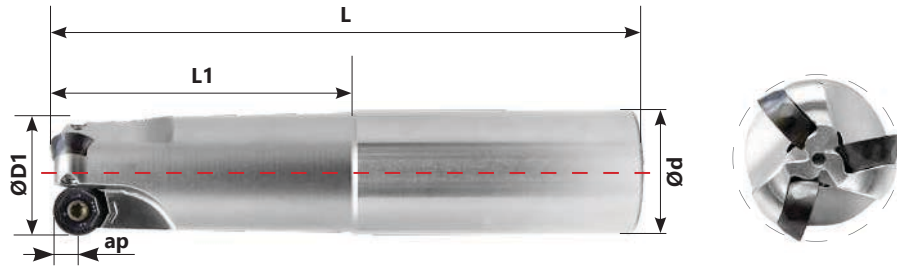
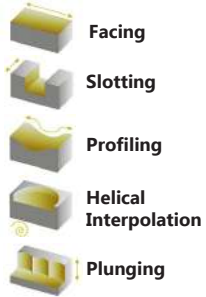

Bestellcode (Ordering Code)	Bezeichnung (Identification)	Platten (Inserts)		Maße (Dimensions) in mm				
		Typ (Type)	Anzahl (Number)	d	D1	L	L1	ap
SW146-20-1	RDSW20102-PFM-WS10-Z2-01	RP... RD... 10	2	20	20	102	50	0.1 - 5
SW146-20-2	RDSW20165-PFM-WS10-Z2-01	RP... RD... 10	2	20	20	165	50	0.1 - 5
SW146-25-1	RDSW25116-PFM-WS10-Z3-01	RP... RD... 10	3	25	25	116	60	0.1 - 5
SW146-25-2	RDSW25165-PFM-WS10-Z3-01	RP... RD... 10	3	25	25	165	60	0.1 - 5
SW146-32-1	RDSW32130-PFM-WS10-Z4-01	RP... RD... 10	4	32	32	130	70	0.1 - 5
SW146-32-2	RDSW32165-PFM-WS10-Z4-01	RP... RD... 10	4	32	32	165	70	0.1 - 5

## RP...RD...

**Aufsteckmesserkopf**  
(Arbor Mounting)

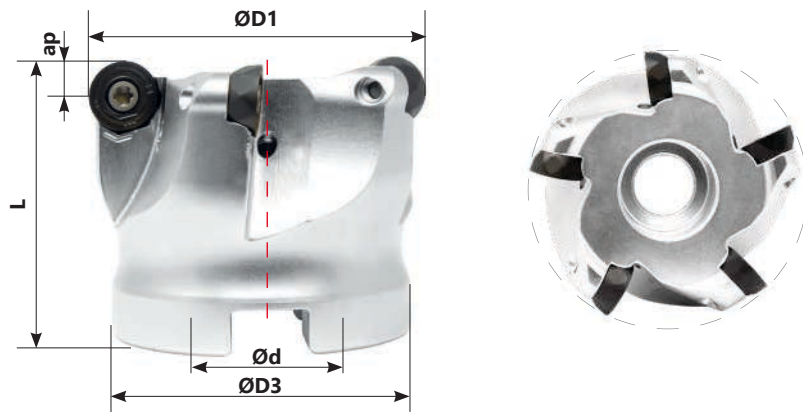
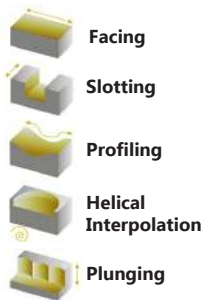

Bestellcode (Ordering Code)	Bezeichnung (Identification)	Platten (Inserts)		Maße (Dimensions) in mm				
		Typ (Type)	Anzahl (Number)	D1	D3	d	L	ap
SW147-40	RDSW40-PFM-AM10-Z4-01	RP... RD... 10	4	40	38	16	40	0.1 - 5
SW147-50	RDSW50-PFM-AM10-Z5-01	RP... RD... 10	5	50	43	22	40	0.1 - 5

## RP...RD...

**Weldonschaft**  
(Weldon Shank)

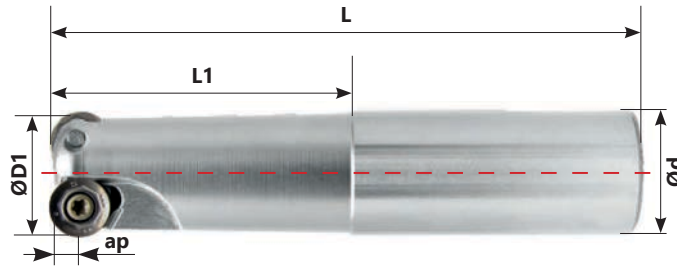
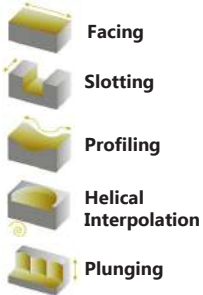

Bestellcode (Ordering Code)	Bezeichnung (Identification)	Platten (Inserts)		Maße (Dimensions) in mm				
		Typ (Type)	Anzahl (Number)	d	D1	L	L1	ap
SW148-25-1	RDSW2586-PFM-WS12-Z2-01	RP... RD... 12	2	25	25	86	30	0.1 - 6
SW148-25-2	RDSW25116-PFM-WS12-Z2-01	RP... RD... 12	2	25	25	116	60	0.1 - 6
SW148-32-1	RDSW32100-PFM-WS12-Z3-01	RP... RD... 12	3	32	32	100	40	0.1 - 6
SW148-32-2	RDSW32130-PFM-WS12-Z3-01	RP... RD... 12	3	32	32	130	70	0.1 - 6

## RP...RD...



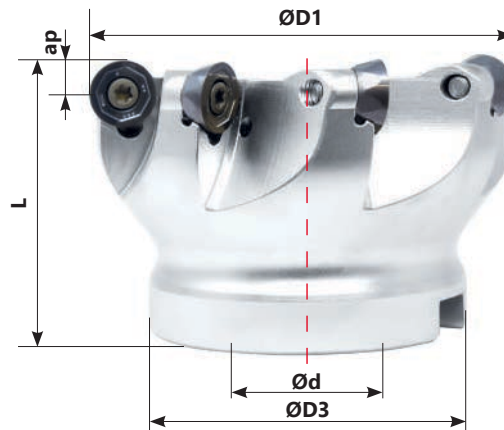
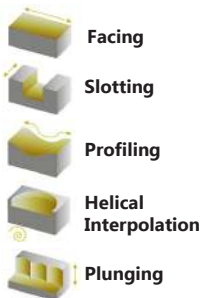

**Aufsteckmesserkopf**  
(Arbor Mounting)



Bestellcode (Ordering Code)	Bezeichnung (Identification)	Platten (Inserts)		Maße (Dimensions) in mm				
		Typ (Type)	Anzahl (Number)	D1	D3	d	L	ap
SW149-40	RDSW40-PFM-AM12-Z4-01	RP... RD... 12	4	40	38	16	40	0.1 - 6
SW149-50	RDSW50-PFM-AM12-Z5-01	RP... RD... 12	5	50	43	22	40	0.1 - 6
SW149-63	RDSW63-PFM-AM12-Z6-01	RP... RD... 12	6	63	48	22	40	0.1 - 6
SW149-80	RDSW80-PFM-AM12-Z8-01	RP... RD... 12	8	80	58	27	50	0.1 - 6
SW149-100	RDSW100-PFM-AM12-Z10-01	RP... RD... 12	10	100	78	32	50	0.1 - 6

**RP...RD...**

**Aufsteckmesserkopf**  
(Arbor Mounting)

-  Facing
-  Slotting
-  Profiling
-  Helical Interpolation
-  Plunging

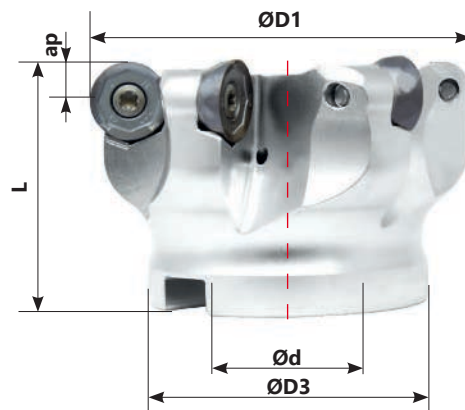

Bestellcode (Ordering Code)	Bezeichnung (Identification)	Platten (Inserts)		Maße (Dimensions) in mm				
		Typ (Type)	Anzahl (Number)	D1	D3	d	L	ap
SW150-50	RDSW50-PFM-AM16-Z3-01	RP... RD... 16	3	50	48	22	40	0.1 - 8
SW150-63	RDSW63-PFM-AM16-Z5-01	RP... RD... 16	5	63	48	22	40	0.1 - 8
SW150-80	RDSW80-PFM-AM16-Z6-01	RP... RD... 16	6	80	58	27	50	0.1 - 8
SW150-100	RDSW100-PFM-AM16-Z7-01	RP... RD... 16	7	100	78	32	50	0.1 - 8
SW150-125	RDSW125-PFM-AM16-Z8-01	RP... RD... 16	8	125	88	40	63	0.1 - 8

# FRÄSPLATTEN (MILLING INSERTS)

Bestellcode (Ordering Code)	Qualität (Grades)										
	P			M		K		N	S		H
	CVD	PVD		PVD	CVD	PVD		UNC	CVD		PVD
	SW22230	SW11235	.	SW11245	SW22535	.	.	SW00915	SW22535	SW22540	SW12115



RPMX 10T3MO-HCM	▲	▲									
-----------------	---	---	--	--	--	--	--	--	--	--	--

RPMX 10T3MO-SCM				▲	▲						
-----------------	--	--	--	---	---	--	--	--	--	--	--



RDHX 10T3MO-LMM							▲				
-----------------	--	--	--	--	--	--	---	--	--	--	--

RPHX 10T3MO-XCM									▲	▲	
-----------------	--	--	--	--	--	--	--	--	---	---	--



RDHW 10T3MOSN											▲
---------------	--	--	--	--	--	--	--	--	--	--	---



RPMX 1204MO-HCM	▲	▲									
-----------------	---	---	--	--	--	--	--	--	--	--	--

RPMX 1204MO-SCM				▲	▲						
-----------------	--	--	--	---	---	--	--	--	--	--	--



RDHX 1204MO-LMM							▲				
-----------------	--	--	--	--	--	--	---	--	--	--	--

RPHX 1204MO-XCM									▲	▲	
-----------------	--	--	--	--	--	--	--	--	---	---	--



RDHW 1204MOSN											▲
---------------	--	--	--	--	--	--	--	--	--	--	---



RPMX 1605MO-HCM	▲	▲									
-----------------	---	---	--	--	--	--	--	--	--	--	--

RPMX 1605MO-SCM				▲	▲						
-----------------	--	--	--	---	---	--	--	--	--	--	--



RPHX 1605MO-XCM									▲	▲	
-----------------	--	--	--	--	--	--	--	--	---	---	--

# SCHNITTDATEN (CUTTING DATA)

Zu bearbeitendes Material (Material to be machined)		HB	Verschleißfestigkeit (Wear Resistance)							Zähigkeit (Toughness)				
			Vc (m/min)							Plattengröße (Insert size)	fz (mm)	ap (mm)		
			SW22230	SW11235	SW11245	SW22535	SW22540	SW00915	SW12115					
<b>P</b>	Unlegierter Stahl (Unalloyed Steel)	155-220	120-220	120-220	-	-	-	-	-	-	-	-	-	
	Niedrig legierter Stahl (Low-Alloyed Steel)	220-280	90-190	90-190	-	-	-	-	-	-	-	RD... 10 RD... 12 RD... 16	≤0,15 ≤0,20 ≤0,25	≤0,50 ≤0,80 ≤0,80
	Hoch legierter Stahl (High-Alloyed Steel)	280-380	60-160	60-160	-	-	-	-	-	-	-	-	-	
<b>M</b>	Rostfreier Stahl, ferritisch (Stainless Steels-Ferritic)	200-330	-	-	100-200	100-200	-	-	-	-	-	RD... 10 RD... 12 RD... 16	≤0,10 ≤0,10 ≤0,20	≤0,15 ≤0,20 ≤0,25
	Rostfreier Stahl, austenitisch (Stainless Steel-Austenitic)	200-330	-	-	60-160	60-160	-	-	-	-	-	-	-	
<b>N</b>	Aluminium und NE-Metalle (Aluminium and Non Ferrous)	30-130	-	-	-	-	-	-	<2000	-	-	RD... 10 RD... 12	≤0,10 ≤0,10	≤0,40 ≤0,50
<b>S</b>	Heat Resistant Super Alloys (Heat Resistant Super Alloys)	200-320	-	-	-	25-75	25-75	-	-	-	-	RD... 10 RD... 12 RD... 16	≤0,08 ≤0,10 ≤0,10	≤0,25 ≤0,30 ≤0,30
<b>H</b>	Gehärteter Stahl (Hardened Steel)	40-55 HRc	-	-	-	-	-	-	-	100-180	-	RD... 10 RD... 12	≤0,10 ≤0,10	≤0,20 ≤0,25

Alle Schnittdaten dienen zur Orientierung (All cutting datas serve to orientation)

## PLATTEN - TECHNISCHE DATEN (INSERTS - TECHNICAL DETAILS)

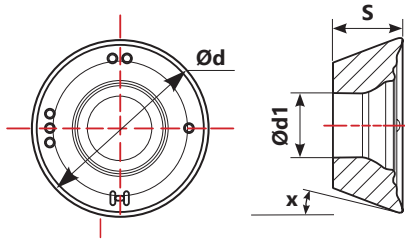

Bestellcode (Ordering Code)	Maße (Dimensions) in mm			
	d	S	d1	x
RP... 10...	10	3.97	3.4	11
RD... 10...	10	3.97	3.4	15
RP... 12...	12	4.76	4.4	11
RD... 12...	12	4.76	4.4	15
RP... 16...	16	5.56	5.5	11

## EMPFOHLENE SCHNITTWERTE (RECOMMENDED PARAMETERS)

Platte (Insert)	Indexing (4 times)		Indexing (8 times)
	ap	ap max	ap max
RD...10	2,50	4,50	1,40
RD...12	3,00	5,50	1,70
RD...16	4,00	7,50	2,30

## SCHNITTDATEN R10 (CUTTING DATA R10)

Startparameter (Starting parameters)

$a_p$  [mm]

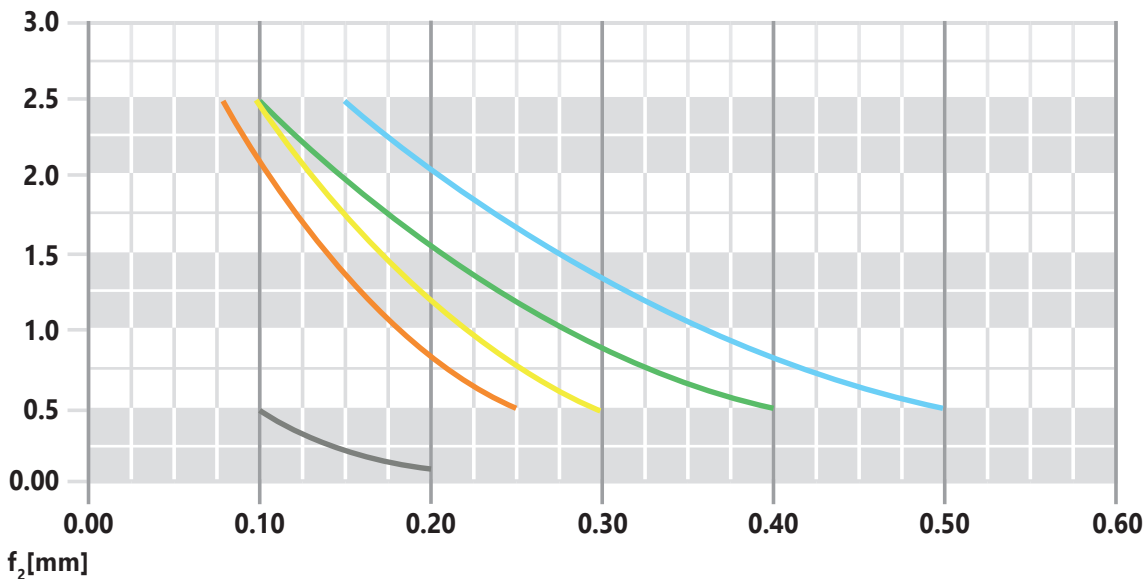

**SCHNITTDATEN R12 (CUTTING DATA R12)**

---

Startparameter (Starting parameters)

$a_p$  [mm]

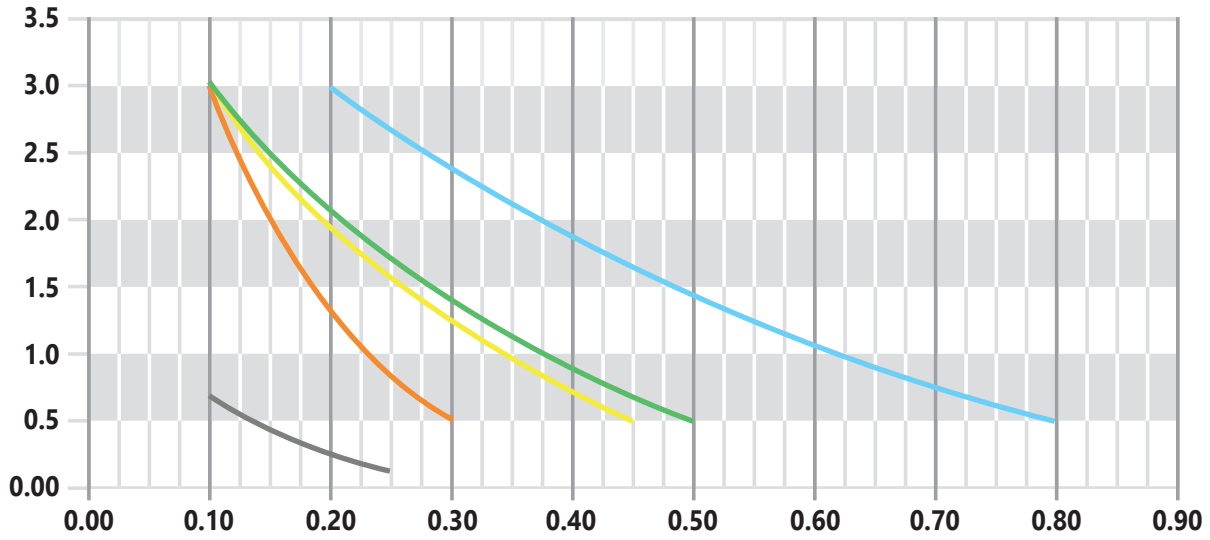

$f_z$  [mm]

**SCHNITTDATEN R16 (CUTTING DATA R16)**

---

Startparameter (Starting parameters)

$a_p$  [mm]

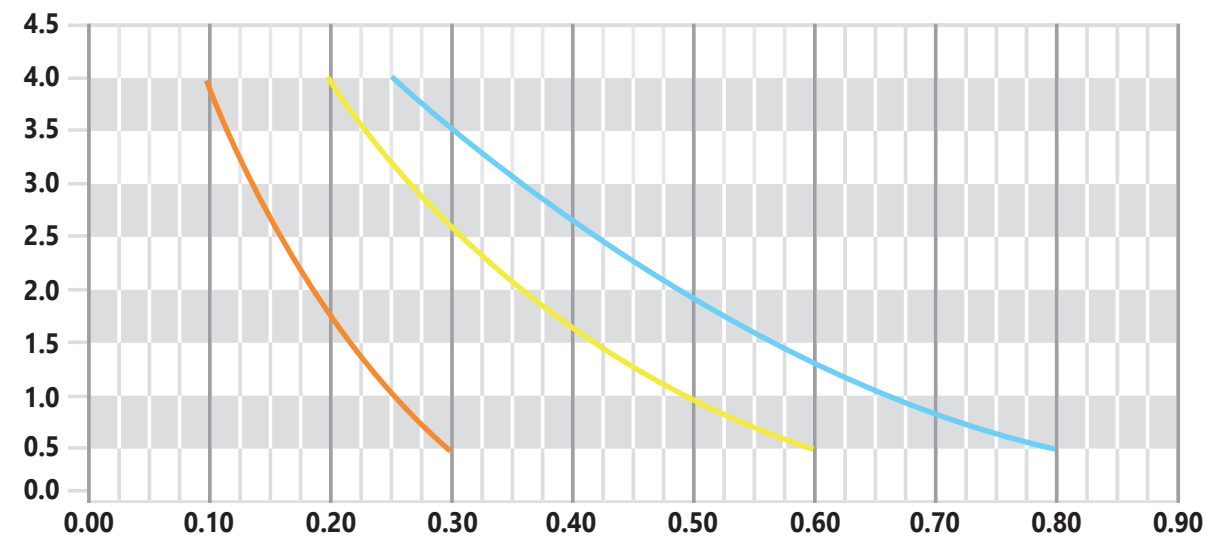

$f_z$  [mm]

**ERSATZTEILE (SPARE PARTS)**

<b>Werkzeugdurchmesser</b> <i>(Tool Diameter)</i> <b>ØDc</b>	<b>Spannschraube</b> <i>(Insert Screw)</i>	<b>Torx Schlüssel</b> <i>(Torx Key)</i>	<b>Unterlegplatte / Unterlegscheibe</b> <i>(Shim / Washer)</i>	<b>Klemmschraube</b> <i>(Screw Clamp)</i>
				
R...10...	SW11689894	-	-	-
R...10...	-	-	-	SW11036880
R...12...AM...	SW4011654	-	-	-
R...12...WS...	SW7818428	-	-	-
RDSW40-PFM-AM12-Z4-01	-	-	-	SW7818267
R...16...	SW4513250	-	-	-
R...16...	SW7818268	-	-	-

# SCHRÄGEINTAUCHEN UND HELIXINTERPOLATION TEN (RAMPING AND HELICAL INTERPOLATION)

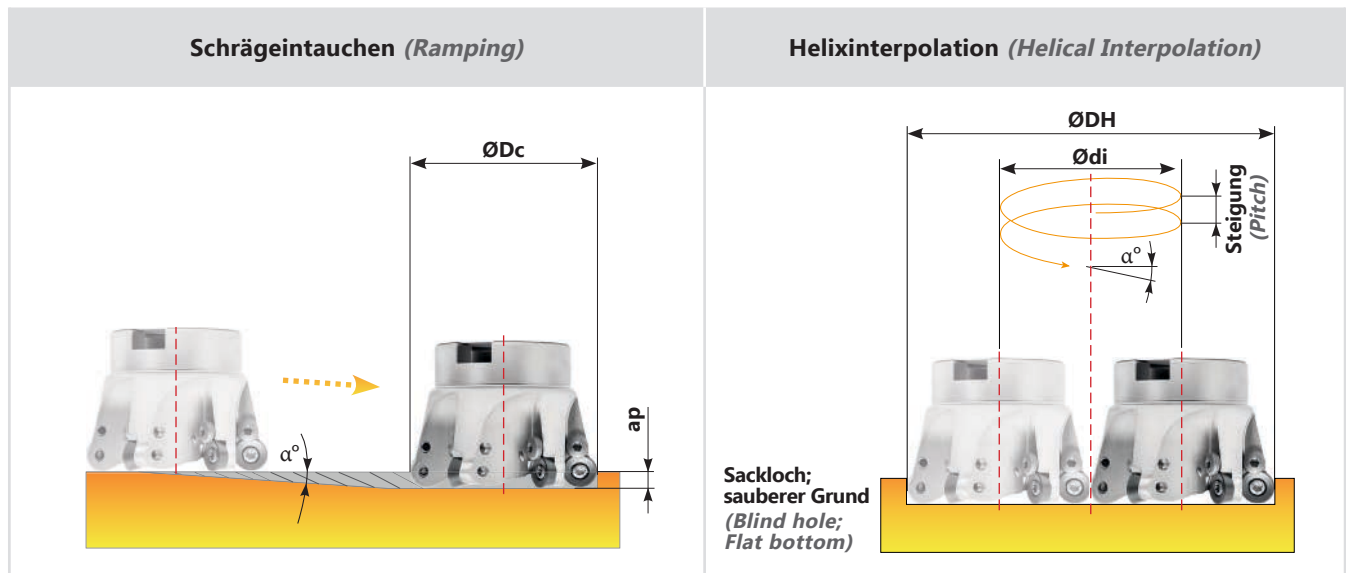

Platte (Insert)	ØDc	Max Ramp α°	Max ap	ØDHmin	ØDHmax	Max Pitch/Rev.
RD... 10...	20	1,3	5	26	30	1,3
	25	2,0	5	37	40	1,8
	32	3,0	5	50	54	1,5
	40	3,3	5	64	70	1,1
	50	2,4	5	68	74	1,1
RD... 12...	25	6,4	6	31	38	2,2
	32	4,0	6	46	52	1,7
	40	2,8	6	62	68	1,4
	50	2,6	6	81	88	1,1
	63	1,9	6	107	114	0,9
	80	1,3	6	142	148	0,7
	100	1,0	6	181	188	0,5
RD... 16...	50	4,0	8	75	84	1,5
	63	2,8	8	101	110	1,1
	80	2,0	8	135	144	0,9
	100	1,5	8	175	184	0,7
	125	1,0	8	225	234	0,5

Während der Helixinterpolation oder des Schrägeintauchens darf der maximale Steigungswinkel α° nicht überschritten werden  
(During helical interpolation or ramping do not exceed max Pitch α°)

**RDSW...WS...**

Weldonschaft  
(Weldon Shank)

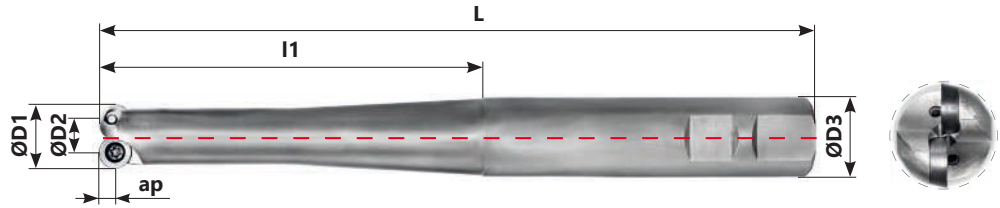

Bestellcode (Ordering Code)	Bezeichnung (Identification)	Platten (Inserts)		Maße (Dimensions) in mm					
		Typ (Type)	Anzahl (Number)	ØD1	ØD2	ØD3	L	l1	ap
SW105-15-1	RDSW15160-PFM-WS07-Z2-03	RD...0702...	2	15	8	16	160	60	0,1-3,5
SW105-15-2	RDSW15220-PFM-WS07-Z2-03	RD...0702...	2	15	8	25	220	120	0,1-3,5
SW105-20-1	RDSW20160-PFM-WS10-Z2-03	RD...1003...	2	20	10	20	160	60	0,1-5,0
SW105-20-2	RDSW20220-PFM-WS10-Z2-03	RD...1003...	2	20	10	25	220	120	0,1-5,0
SW105-25-1	RDSW25220-PFM-WS12-Z2-03	RD...12T3...	2	25	13	25	220	120	0,1-6,0
SW105-25-2	RDSW25230-PFM-WS12-Z2-03	RD...12T3...	2	25	13	32	230	130	0,1-6,0

**RDSW...TC...**

Einschraubmesserkopf  
(Threaded Coupling)

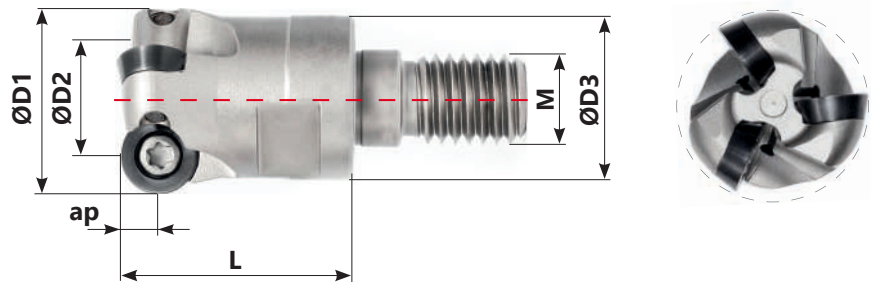

Bestellcode (Ordering Code)	Bezeichnung (Identification)	Platten (Inserts)		Maße (Dimensions) in mm					
		Typ (Type)	Anzahl (Number)	ØD1	ØD2	ØD3	M	L	ap
SW106-15	RDSW15-PFM-TC07-Z3-03	RD...0702...	3	15	8	13	M8	20	0,1-3,5
SW106-16-1	RDSW16-PFM-TC07-Z2-03	RD...0702...	2	16	9	13	M8	20	0,1-3,5
SW106-16-2	RDSW16-PFM-TC07-Z3-03	RD...0702...	3	16	9	13	M8	20	0,1-3,5
SW106-20-1	RDSW20-PFM-TC10-Z4-03	RD...0702...	4	20	13	18	M10	25	0,1-3,5
SW106-20-2	RDSW20-PFM-TC10-Z2-03	RD...1003...	2	20	10	18	M10	25	0,1-5,0
SW106-25	RDSW25-PFM-TC10-Z3-03	RD...1003...	3	25	15	21	M12	30	0,1-5,0
SW106-30	RDSW30-PFM-TC10-Z4-03	RD...1003...	4	30	20	29	M16	35	0,1-5,0
SW106-35-1	RDSW35-PFM-TC10-Z5-03	RD...1003...	5	35	25	29	M16	43	0,1-5,0
SW106-42-1	RDSW42-PFM-TC10-Z5-03	RD...1003...	5	42	32	29	M16	40	0,1-5,0
SW106-24	RDSW24-PFM-TC12-Z2-03	RD...12T3...	2	24	12	21	M16	32	0,1-6,0
SW106-35-2	RDSW35-PFM-TC12-Z3-03	RD...12T3...	3	35	23	29	M16	42	0,1-6,0
SW106-42-2	RDSW42-PFM-TC12-Z4-03	RD...12T3...	4	42	30	29	M16	42	0,1-6,0

# PLANFRÄSEN / PROFILFRÄSEN SW105-107 (FACE MILLING / PROFILING SW105-107)

## RDSW...AM...

Aufsteckmesserkopf  
(Arbor Mounting)

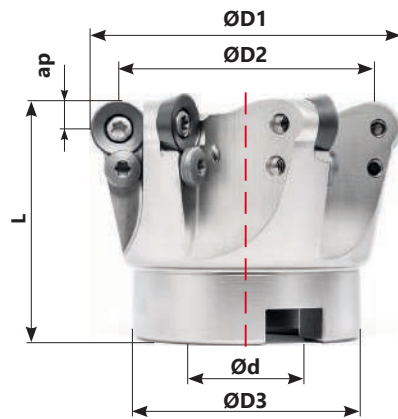

Bestellcode (Ordering Code)	Bezeichnung (Identification)	Platten (Inserts)		Maße (Dimensions) in mm					
		Typ (Type)	Anzahl (Number)	ØD1	ØD2	ØD3	Ød	L	ap
SW107-42	RDSW42-PFM-AM10-Z6-03	RD...1003...	6	42	36	32	16	44	0,1-5,0
SW107-52	RDSW52-PFM-AM10-Z7-03	RD...1003...	7	52	40	42	22	50	0,1-5,0

AXIAL ANGLE = 0°









SW107-52-1	RDSW52A0-PFM-AM12-Z5-03	RD...12T3...	5	52	40	40	22	50	0,1-6,0
SW107-66-1	RDSW66A0-PFM-AM12-Z6-03	RD...12T3...	6	66	48	54	27	50	0,1-6,0
SW107-80-1	RDSW80A0-PFM-AM12-Z7-03	RD...12T3...	7	80	60	68	27	50	0,1-6,0

AXIAL ANGLE = 7°

SW107-50	RDSW50A7-PFM-AM12-Z5-03	RD...12T3...	5	50	40	38	22	50	0,1-6,0
SW107-52-2	RDSW52A7-PFM-AM12-Z5-03	RD...12T3...	5	52	40	40	22	50	0,1-6,0
SW107-66-2	RDSW66A7-PFM-AM12-Z6-03	RD...12T3...	6	66	48	54	27	50	0,1-6,0
SW107-80-2	RDSW80A7-PFM-AM12-Z7-03	RD...12T3...	7	80	60	68	27	52,5	0,1-6,0

# FRÄSPLATTEN (MILLING INSERTS)

Bestellcode (Ordering Code)	Qualität (Grades)												
	P						M	K			N	S	H
	PVD						PVD	PVD			UNC	PVD	PVD
	SW11103	SW11910	SW11920	SW11125	SW11135	SW11740	SW11920	SW11910	SW11920	SW11740	SW00910	SW11740	SW11103

	RDHW 0702 M0T	▲	▲	▲																▲
	RDHW 1003 M0T	▲	▲	▲		▲														▲
	RDHT 1003 M0T					▲	▲													
	RDMT 1003 M0T					▲	▲													
	RDMW 1003 M0T				▲	▲	▲													
	RDHW 12T3 M0T	▲	▲	▲		▲														▲
	RDHT 12T3 M0S-MP				▲															▲
	RDHT 12T3 M0T					▲	▲													
	RDMT 12T3 M0T					▲	▲													
	RDMW 12T3 M0T					▲	▲	▲												

## PLATTEN - TECHNISCHE DATEN (INSERTS - TECHNICAL DETAILS)

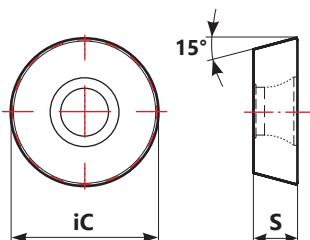

Bestellcode (Ordering Code)	Maße (Dimensions) in mm	
	iC	S
RD...07...	7,00	2,38
RD...10...	10,00	3,18
RD...12...	12,00	3,97

# SCHNITTDATEN (CUTTING DATA)

Zu bearbeitendes Material (Material to be machined)		HB	Verschleißfestigkeit (Wear Resistance) Vc (m/min) Zähigkeit (Toughness)						Vorschub/Zahn (feed/tooth) in mm		
			SW11103	SW11910	SW11920	SW11125	SW11135	SW11740	Plattengröße (Insert size)	fz (mm)	ap (mm)
<b>P</b>	Unlegierter Stahl (Unalloyed Steel)	125-220	180-300	180-250	150-230	160-190	150-180	130-160	RD...07	≤0,18	≤1,50
									RD...10	≤0,24	≤2,50
									RD...12	≤0,27	≤2,50
	Niedrig legierter Stahl (Low-Alloyed Steel)	220-280	180-250	170-210	140-220	140-180	140-170	120-150	RD...07	≤0,18	≤1,50
									RD...10	≤0,24	≤2,50
									RD...12	≤0,25	≤2,50
Hoch legierter Stahl (High-Alloyed Steel)	280-380	180-230	160-200	130-180	130-160	120-150	100-130	RD...07	≤0,15	≤1,50	
								RD...10	≤0,21	≤2,50	
								RD...12	≤0,20	≤2,50	
<b>K</b>	Temperguss (Malleable Cast Iron)	130-230	-	170-300	150-280	-	-	130-250	RD...07	≤0,20	≤1,50
									RD...10	≤0,25	≤2,50
									RD...12	≤0,24	≤2,50
	Grauguss (Grey Cast Iron)	180-245	-	150-250	130-230	-	-	110-220	RD...07	≤0,20	≤1,50
									RD...10	≤0,25	≤2,50
									RD...12	≤0,24	≤2,50
	Gusseisen mit Kugelgraphit (Spheroidal Cast Iron)	160-250	-	90-210	80-190	-	-	80-170	RD...07	≤0,18	≤1,50
									RD...10	≤0,22	≤2,50
									RD...12	≤0,22	≤2,50
<b>N</b>	Aluminium und NE-Metalle (Aluminium and Non Ferrous)	30-130	-	-	-	-	-	-	RD...07	≤0,45	≤1,50
									RD...10	≤0,80	≤2,50
									RD...12	-	-
<b>H</b>	Gehärteter Stahl (Hardened Steel)	40-55 HRC	120-240	-	-	-	-	-	RD...07	≤0,12	≤1,50
									RD...10	≤0,18	≤2,50
									RD...12	≤0,18	≤2,50

Platte (Insert)	Vorschub/Zahn (feed/tooth)								
	0,20-0,50	0,50-1,00	2,00	3,00	4,00	5,00	6,00	7,00	8,00
RD...07	0,35	0,25	0,10	0,07	-	-	-	-	-
RD...10	-	0,40	0,35	0,30	0,20	-	-	-	-
RD...12	-	0,50	0,45	0,30	0,25	0,22	-	-	-

Alle Schnittdaten dienen zur Orientierung  
(All cutting datas serve to orientation)

# SCHRÄGEINTAUCHEN UND HELIXINTERPOLATION (RAMPING AND HELICAL INTERPOLATION)

Schrägeintauchen (Ramping)				Helixinterpolation (Helical Interpolation)		
				<p>Sackloch; sauberer Grund (Blind hole; Flat bottom)</p>		
Platte (Insert)	ØDc	Max Ramp α°	Max ap	ØDHmin	ØDHmax	Max Pitch/Rev.
RD...07...	15	9,4°	3,5	23,0	30,0	7,0
	16	8°	3,5	25,0	32,0	7,0
	20	6°	3,5	33,0	40,0	6,0
RD...10...	20	25,0°	5,0	30,0	40,0	29,0
	25	22,0°	5,0	40,0	50,0	31,0
	30	13,5°	5,0	50,0	60,0	22,0
	35	12,0°	5,0	60,0	70,0	23,0
	42	10,0°	5,0	74,0	84,0	23,0
	52	7,0°	5,0	94,0	104,0	20,0
RD...12...	24	17,0°	6,0	36,0	48,0	23,0
	25	16,2°	6,0	38,0	50,0	22,0
	35	12,0°	6,0	58,0	70,0	23,0
	42	10,3°	6,0	72,0	84,0	23,0
	50	6,4°	6,0	88,0	100,0	17,0
	52	6,0°	6,0	92,0	104,0	17,0
	66	3,5°	6,0	120,0	132,0	15,0
	80	2,5°	6,0	148,0	160,0	14,0

Während der Helixinterpolation oder des Schrägeintauchens darf der maximale Steigungswinkel  $\alpha^\circ$  nicht überschritten werden  
(During helical interpolation or ramping do not exceed max Pitch  $\alpha^\circ$ )

# ZUBEHÖR FÜR SW105-107 (EQUIPMENT FOR SW105-107)

## ERSATZTEILE (SPARE PARTS)

Werkzeughdurchmesser (Tool Diameter) ØDc	Spannschraube (Insert Screw)	Torx Schlüssel (Torx Key)	Unterlegplatte / Unterlegscheibe (Shim / Washer)	Klemmschraube (Screw Clamp)
RDSW...WS/TC...Ø15-Ø20	SW5250503	XT08	-	-
RDSW...TC/AM...Ø20-Ø52	SW5350800	XT15	-	-
RDSW...A7/A0...Ø50-Ø80	SW5350800	XT15	-	-
-	-	-	-	-

# PLANFRÄSEN (FACE MILLING)

## RN...RO...

Aufsteckmesserkopf  
(Arbor Mounting)

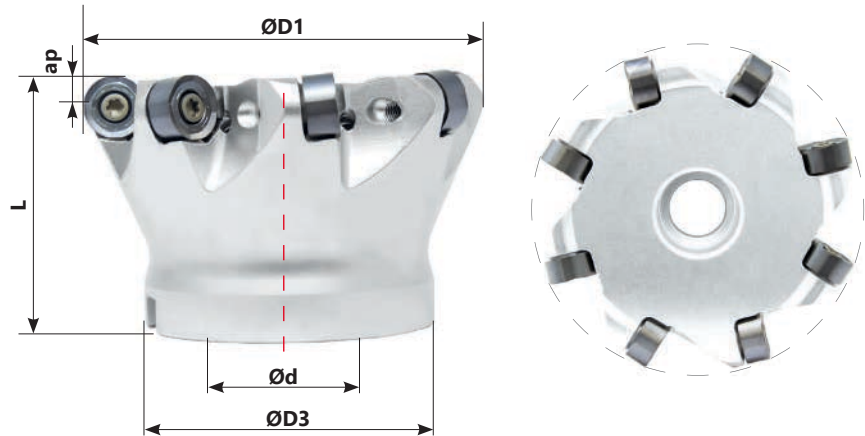

Bestellcode (Ordering Code)	Bezeichnung (Identification)	Platten (Inserts)		Maße (Dimensions) in mm				
		Typ (Type)	Anzahl (Number)	d	D1	D3	L	ap
SW143-63	RNROSW63-FM-AM16-Z5-01	RN... RO...	5	22	63	38	40	0.5-4.0

# FRÄSPLATTEN (MILLING INSERTS)

Bestellcode (Ordering Code)	Qualität (Grades)									
	P		M		K			N	S	H
	CVD	PVD	PVD	CVD	PVD			UNC	CVD	PVD
	SW22230	SW11235	SW11245	SW22535	.	.	.	SW00915	SW22535	.



RNKU 1204MOER-HCM

▲	▲								
---	---	--	--	--	--	--	--	--	--



ROHU 1204MOER-SCM

		▲	▲						
--	--	---	---	--	--	--	--	--	--



RNKU 1604MOER-HCM

▲	▲								
---	---	--	--	--	--	--	--	--	--



ROHU 1604MOER-SCM

		▲	▲						
--	--	---	---	--	--	--	--	--	--

## PLATTEN - TECHNISCHE DATEN (INSERTS - TECHNICAL DETAILS)

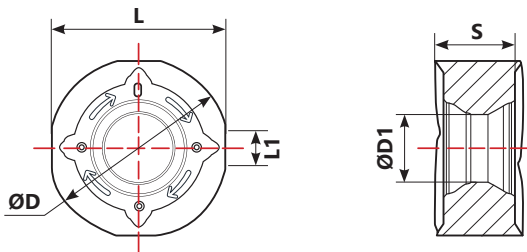

Bestellcode (Ordering Code)	Maße (Dimensions) in mm				
	D	D1	S	L1	X
RNKU... 12...	12	4.5	5.9	11.8	0
ROHU... 12...	12	4.5	5.9	11.8	3
RNKU... 16...	16	5.8	6.7	15.7	0
ROHU... 16...	16	5.8	6.7	15.7	3

# SCHNITTDATEN (CUTTING DATA)

Zu bearbeitendes Material (Material to be machined)		HB	Verschleißfestigkeit (Wear Resistance)					Vc (m/min)		Zähigkeit (Toughness)		Vorschub/Zahn (feed/tooth) in mm		
			SW22230		SW11235		SW12240		SW22535		SW22415		R...12...	R...16...
<b>P</b>	Unlegierter Stahl (Unalloyed Steel)	155-220	120-220	120-220	-	-	-	-	-	-	-	0,2-0,8	0,25-0,8	
	Niedrig legierter Stahl (Low-Alloyed Steel)	220-280	100-200	100-20	-	-	-	-	-	-	-	0,2-0,8	0,25-0,8	
	Hoch legierter Stahl (High-Alloyed Steel)	280-380	60-150	60-150	-	-	-	-	-	-	-	0,2-0,8	0,25-0,8	
<b>M</b>	Rostfreier Stahl, ferritisch (Stainless Steels-Ferritic)	200-330	-	-	100-200	100-200	-	-	-	-	-	0,1-0,45	0,2-0,6	
	Rostfreier Stahl, austenitisch (Stainless Steel-Austenitic)	200-330	-	-	60-150	60-150	-	-	-	-	-	0,1-0,45	0,2-0,6	

Alle Schnittdaten dienen zur Orientierung (All cutting datas serve to orientation)

**SCHNITTDATEN RNKU/ROHU (CUTTING DATA RNKU/ROHU)**

Startparameter R12 (Starting parameters R12)

$a_p$ [mm]

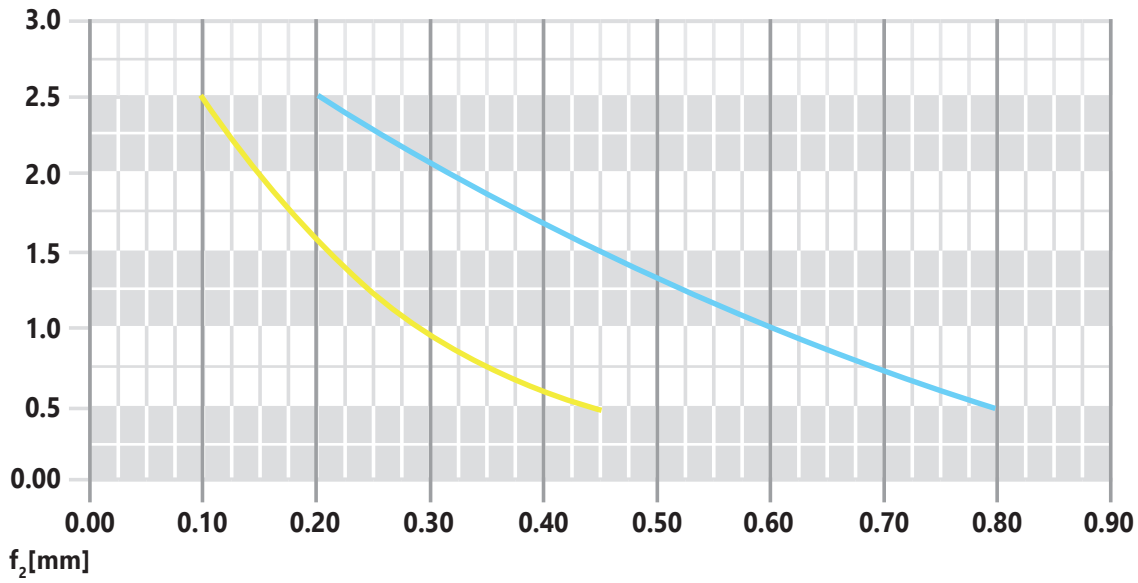

Startparameter R16 (Starting parameters R16)

$a_p$ [mm]

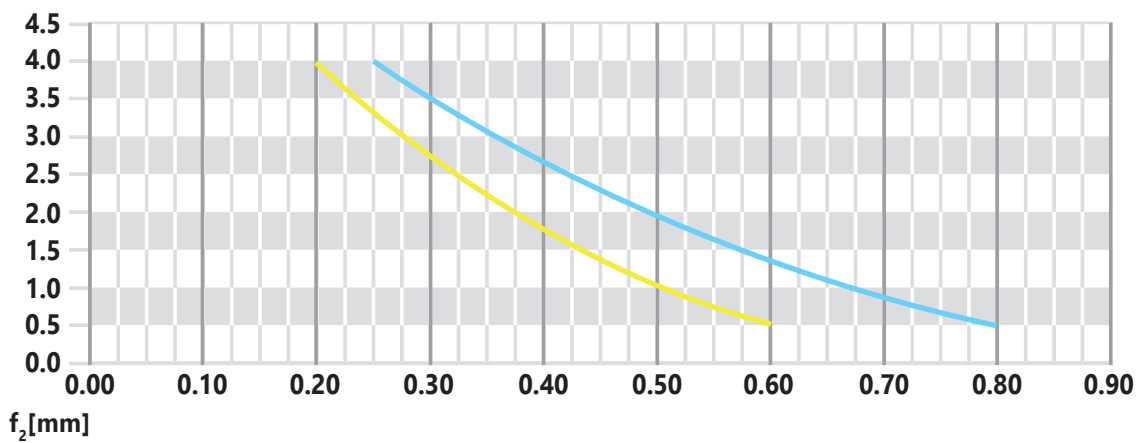

**EMPFOHLENE SCHNITTWERTE (RECOMMENDED PARAMETERS)**

Platte (Insert)	Indexing (4 times)		Indexing (8 times)
	ap	ap max	ap max
RN... RO... 12...	3.0	5.5	1.7
RN... RO... 16...	4.0	7.5	2.3

**ERSATZTEILE (SPARE PARTS)**

Werkzeugdurchmesser (Tool Diameter) ØDc	Spannschraube (Insert Screw)	Torx Schlüssel (Torx Key)	Unterlegplatte / Unterlegscheibe (Shim / Washer)	Klemmschraube (Screw Clamp)
				
RNROSW...AM...	SW1345432		-	-
RNROSW...WS...	SW11037484	-	-	-



**PRODUKTBEZEICHNUNG (PRODUCT IDENTIFICATION)**

**BEISPIEL (EXAMPLE): RDSW 42-PFM-TC 12-Z6-01**

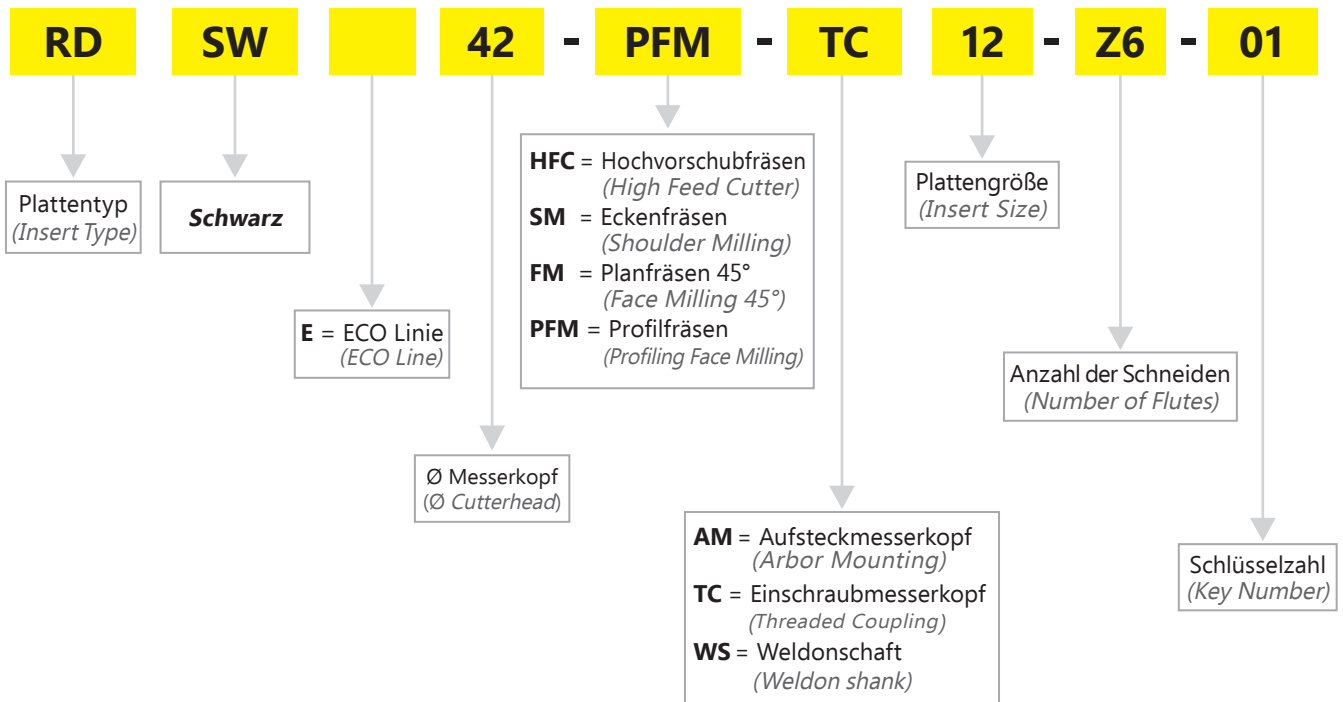

# FORCE LINE

HOCHVORSCHUBFRÄSEN  
(HIGH-FEED)



# HOCHVORSCHUBFRÄSEN SW115-119 (HIGH-FEED SW115-119)

## XSW...WS...

Weldonschaft  
(Weldon Shank)



- Facing
- Helical Interpolation
- Plunging & Recessing
- Slotting

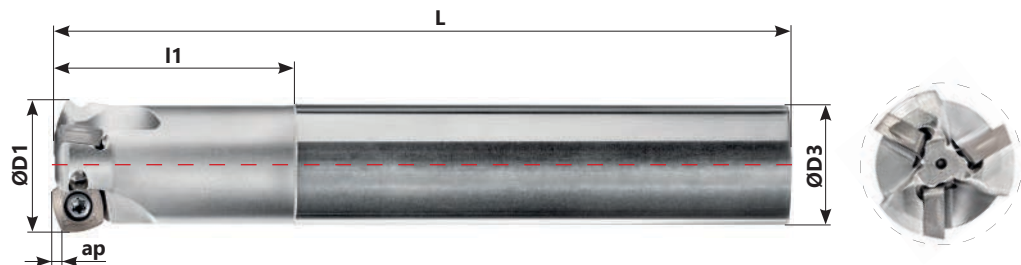

Bestellcode (Ordering Code)	Bezeichnung (Identification)	Platten (Inserts)		Maße (Dimensions) in mm				
		Typ (Type)	Anzahl (Number)	ØD1	ØD3	L	l1	ap
SW115-16	XSW16-HFC-WS07-Z2-01	X...07...	2	16	16	200	50	0,1-0,8
SW115-20	XSW20-HFC-WS07-Z3-01	X...07...	3	20	20	200	50	0,1-0,8
SW115-25	XSW25-HFC-WS07-Z4-01	X...07...	4	25	25	200	50	0,1-0,8
SW117-25	XSW25-HFC-WS10-Z3-01	X...10...	3	25	25	225	50	0,1-1,0
SW119-35	XSW35-HFC-WS13-Z3-01	X...13...	3	35	32	250	63	0,1-2,0

## XSW...TC...

Einschraubmesserkopf  
(Threaded Coupling)



- Facing
- Helical Interpolation
- Plunging & Recessing
- Slotting

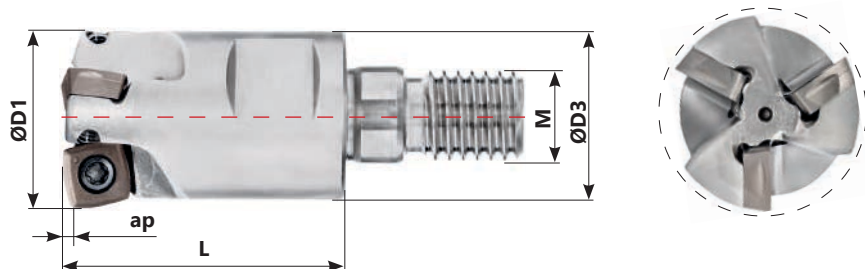





Bestellcode (Ordering Code)	Bezeichnung (Identification)	Platten (Inserts)		Maße (Dimensions) in mm				
		Typ (Type)	Anzahl (Number)	ØD1	ØD3	M	L	ap
SW116-16	XSW16-HFC-TC07-Z2-01	X...07...	2	16	13,8	M8	26	0,1-0,8
SW116-20	XSW20-HFC-TC07-Z3-01	X...07...	3	20	18	M10	30	0,1-0,8
SW116-25	XSW25-HFC-TC07-Z4-01	X...07...	4	25	21	M12	34	0,1-0,8

# HOCHVORSCHUBFRÄSEN SW115-119 (HIGH-FEED SW115-119)

## XSW...AM...

Aufsteckmesserkopf  
(Arbor Mounting)



-  Facing
-  Helical Interpolation
-  Plunging & Recessing
-  Slotting

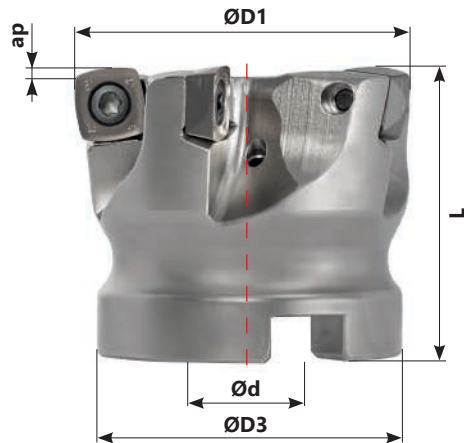

Bestellcode (Ordering Code)	Bezeichnung (Identification)	Platten (Inserts)		Maße (Dimensions) in mm				
		Typ (Type)	Anzahl (Number)	ØD1	ØD3	Ød	L	ap
SW118-40	XSW40-HFC-AM10-Z4-01	X...10...	4	40	38	16	40	0,1-1,0
SW118-50	XSW50-HFC-AM10-Z5-01	X...10...	5	50	43	22	40	0,1-1,0
SW118-63	XSW63-HFC-AM10-Z6-01	X...10...	6	63	48	22	40	0,1-1,0
SW119-50	XSW50-HFC-AM13-Z4-01	X...13...	4	50	43	22	40	0,1-2,0
SW119-63	XSW63-HFC-AM13-Z5-01	X...13...	5	63	48	22	40	0,1-2,0
SW119-80	XSW80-HFC-AM13-Z7-01	X...13...	7	80	58	27	50	0,1-2,0

# FRÄSPLATTEN (MILLING INSERTS)

Bestellcode (Ordering Code)	Qualität (Grades)										
	P		M		K			N	S	H	
	CVD	PVD		PVD	CVD	PVD			UNC	PVD	PVD
	SW22230	SW11235	.	SW11245	SW22535	.	.	.	SW00915	.	.



XPLT 070305SR-HCM

▲	▲									
---	---	--	--	--	--	--	--	--	--	--



XPLT 070305ER-SCM

			▲	▲						
--	--	--	---	---	--	--	--	--	--	--



XDLT 10T308SR-HCM

▲	▲									
---	---	--	--	--	--	--	--	--	--	--



XDLT 10T308ER-SCM

			▲	▲						
--	--	--	---	---	--	--	--	--	--	--



XDLX 10T308SR-HCM

▲	▲									
---	---	--	--	--	--	--	--	--	--	--



XDLX 10T308SR-SCM

			▲	▲						
--	--	--	---	---	--	--	--	--	--	--



XOLT 130410SR-HCM

▲	▲									
---	---	--	--	--	--	--	--	--	--	--



XOLT 130410ER-SCM

			▲	▲						
--	--	--	---	---	--	--	--	--	--	--

# SCHNITTDATEN (CUTTING DATA)

## PLATTEN - TECHNISCHE DATEN (INSERTS - TECHNICAL DETAILS)

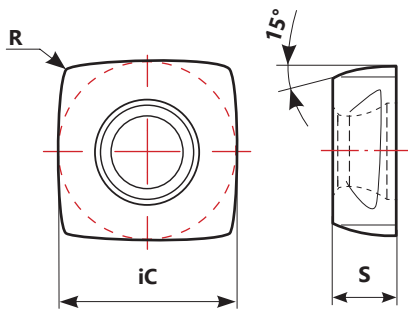

Bestellcode (Ordering Code)	Maße (Dimensions) in mm		
	iC	S	R
XPLT 070305SR-HCM	7	2,75	0,5
XPLT 070305ER-SCM	7	2,75	0,5
XDLT 10T308SR-HCM	10	3,97	0,8
XDLT 10T308ER-SCM	10	3,97	0,8
XOLT 130410SR-HCM	13	4,76	1,0
XOLT 130410ER-SCM	13	4,76	1,0

	Zu bearbeitendes Material (Material to be machined)	HB	Verschleißfestigkeit (Wear Resistance)						Zähigkeit (Toughness)		Vorschub/Zahn (feed/tooth) in mm		
			Vc (m/min)										
			SW22230	SW11235	SW11245	SW22535	SW22415	SW00915	HFC07	HFC10	HFC13		
<b>P</b>	Unlegierter Stahl (Unalloyed Steel)	155-220	110-280	100-240	-	150-260	-	-	0,1-1,5	0,1-2,5	0,1-3,0		
	Niedrig legierter Stahl (Low-Alloyed Steel)	220-280	100-250	90-220	-	80-220	-	-					
	Hoch legierter Stahl (High-Alloyed Steel)	280-380	60-130	60-110	-	90-180	-	-					
<b>M</b>	Rostfreier Stahl, ferritisch (Stainless Steels-ferritic)	200-330	-	110-150	110-160	220-350	-	-	0,1-1,5	0,1-2,5	0,1-3,0		
	Rostfreier Stahl, austenitisch (Stainless Steel-austenitic)	200-330	-	110-150	110-170	150-240	-	-					
<b>K</b>	Temperguss (Malleable Cast Iron)	130-230	100-190	-	-	-	200-320	120 - 200	-	0,1-2,5	0,1-3,0		
	Grauguss (Grey Cast Iron)	180-245	100-310	-	-	-	100 - 190	90 - 160					
	Gusseisen mit Kugelgraphit (Spheroidal Cast Iron)	160-250	90-200	-	-	-	100 - 180	90 - 170					
<b>N</b>	Aluminium und NE-Metalle (Aluminium and Non Ferrous)	30-130	-	-	-	-	-	60 - 1500	0,1-3,0	0,1-3,0	0,1-3,0		
<b>S</b>	Hitzebeständige Superlegierungen (Heat Resistant Super Alloys)	200-320	-	-	-	25-75	-	-	0,1-0,5	0,1-0,8	0,1-1,0		

Alle Schnittdaten dienen zur Orientierung  
(All cutting datas serve to orientation)

# SCHRÄGEINTAUCHEN UND HELIXINTERPOLATION (RAMPING AND HELICAL INTERPOLATION)

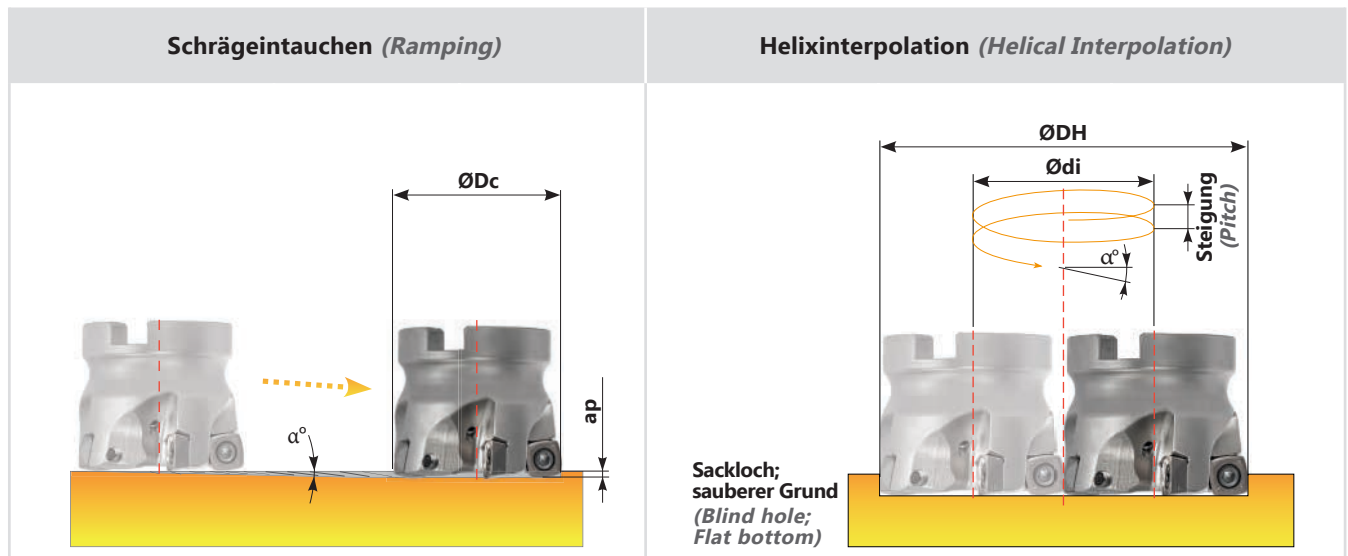

Platte (Insert)	ØDc	Max Ramp α°	Max ap	ØDHmin	ØDHmax	Max Pitch/Rev.
XP...07...	16	5.9°	0,8	22	31	4,5
	20	3.2°	0,8	30	39	2,3
	25	2.0°	0,8	40	49	1,3
	16	5.9°	0,8	22	31	4,5
	20	3.2°	0,8	30	39	2,3
	25	2.0°	0,8	40	49	1,3
XD...10...	25	3.6°	1,0	35	48	3,1
	40	1.2°	1,0	65	78	1,0
	50	0.9°	1,0	85	98	0,8
	63	0.8°	1,0	111	124	0,7
XO...13...	35	4.4°	2,0	50	68	3,7
	50	1.5°	2,0	80	98	1,3
	63	1.1°	2,0	106	124	0,9
	80	1.3°	2,0	140	158	1,1

Während der Helixinterpolation oder des Schrägeintauchens darf der maximale Steigungswinkel α° nicht überschritten werden  
(During helical interpolation or ramping do not exceed max Pitch α°)

# ZUBEHÖR FÜR SW115-119 (EQUIPMENT FOR SW115-119)

## ERSATZTEILE (SPARE PARTS)

Werkzeughdurchmesser (Tool Diameter) ØDc	Spannschraube (Insert Screw)	Torx Schlüssel (Torx Key)	Unterlegplatte / Unterlegscheibe (Shim / Washer)	Klemmschraube (Screw Clamp)
XSW...07...	SW5255008 M2,5 x 5,0 	T08 	-	-
XSW...WS10...	SW5772211 M3,5 x 7,2	T15	-	-
XSW...AM10...	SW5788320 M3,5 x 8,6	T15	-	-
XSW...AM10...Ø40	SW5781826 M8,0 x 30,0	-	-	-
XSW...AM13...	SW5782211 M4.5 x 10.5	T20	-	-



**PRODUKTBEZEICHNUNG (PRODUCT IDENTIFICATION)**

**BEISPIEL (EXAMPLE): RDSW 42-PFM-TC 12-Z6-01**

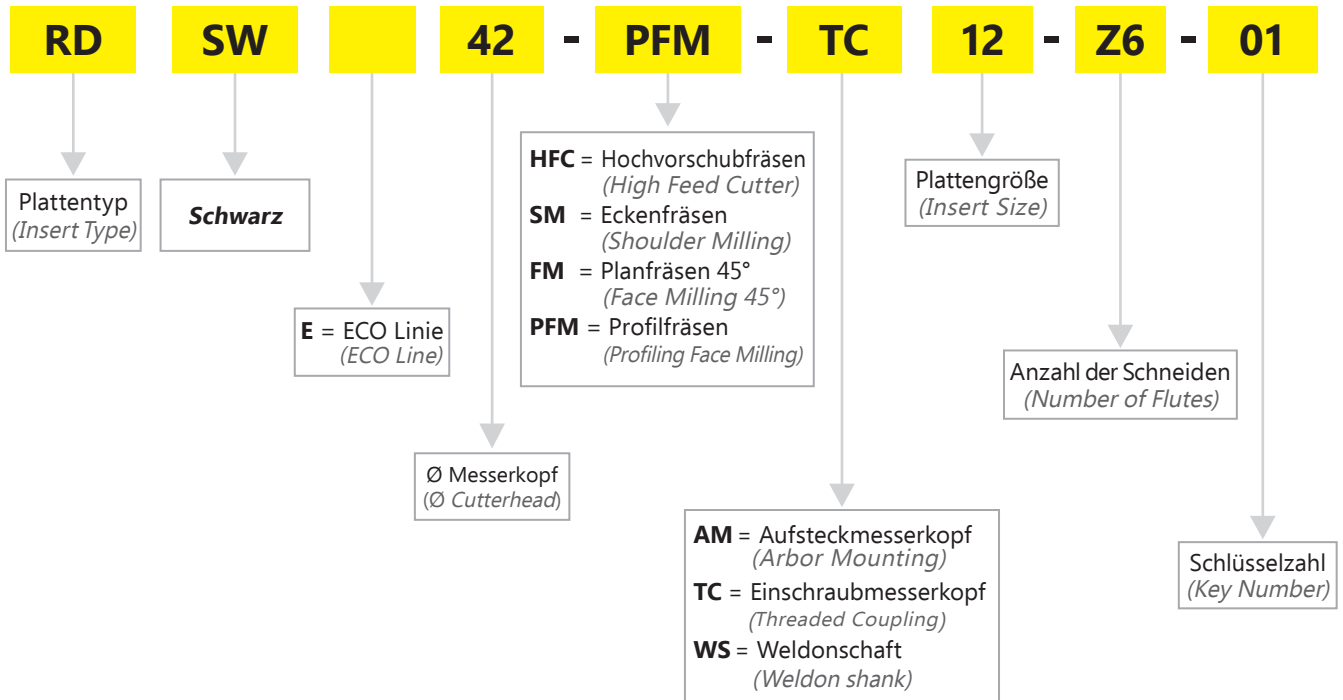

# FORCE LINE

**ECKFRÄSEN  
(SHOULDER MILLING)**



**WNSW...WS...**

Weldonschaft  
(Weldon Shank)

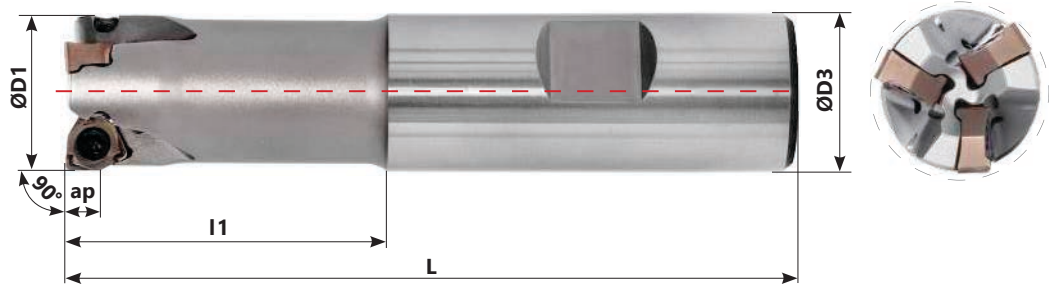

Bestellcode (Ordering Code)	Bezeichnung (Identification)	Platten (Inserts)		Maße (Dimensions) in mm				
		Typ (Type)	Anzahl (Number)	ØD1	ØD3	L	l1	ap
SW132-20	WNSW20-PFM-WS04-Z3-02	WN...04...	3	20	20	100	30	0,4-4,0
SW132-25	WNSW25-PFM-WS04-Z3-02	WN...04...	4	25	25	115	35	0,4-4,0
SW132-32	WNSW32-PFM-WS04-Z5-02	WN...04...	5	32	25	125	40	0,4-4,0
SW133-20	WNSW20-PFM-WS04-Z3-02	WN...04...	3	20	20	150	40	0,4-4,0
SW133-25	WNSW25-PFM-WS04-Z4-02	WN...04...	4	25	25	170	50	0,4-4,0
SW133-32	WNSW32-PFM-WS04-Z5-02	WN...04...	5	32	32	195	70	0,4-4,0

**WNSW...AM04...**

Aufsteckmesserkopf  
(Arbor Mounting)

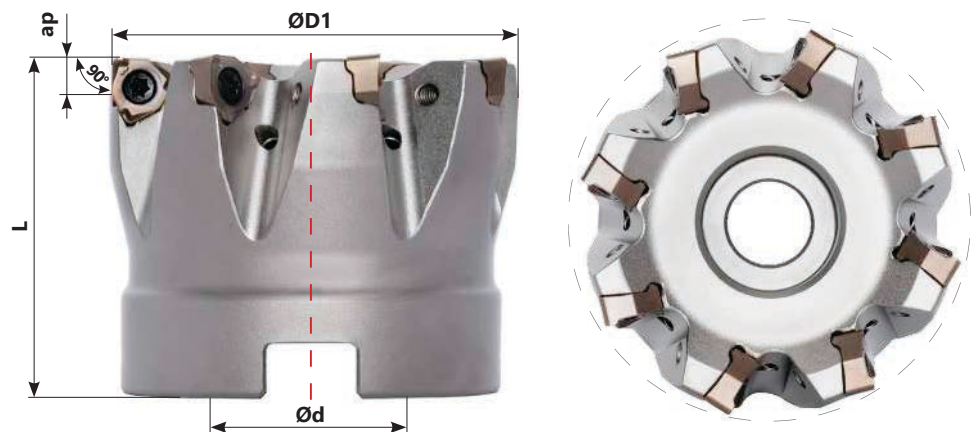

Bestellcode (Ordering Code)	Bezeichnung (Identification)	Platten (Inserts)		Maße (Dimensions) in mm			
		Typ (Type)	Anzahl (Number)	ØD1	Ød	L	ap
SW134-32	WNSW32-PFM-AM04-Z6-02	WN...04...	6	32	16	40	0,4-4,0
SW134-40	WNSW40-PFM-AM04-Z6-02	WN...04...	6	40	16	40	0,4-4,0
SW134-50	WNSW50-PFM-AM04-Z8-02	WN...04...	8	50	22	50	0,4-4,0

# ECKFRÄSEN SW132-135 (SHOULDER MILLING SW132-135)

## WNSW...AM08...

Aufsteckmesserkopf  
(Arbor Mounting)

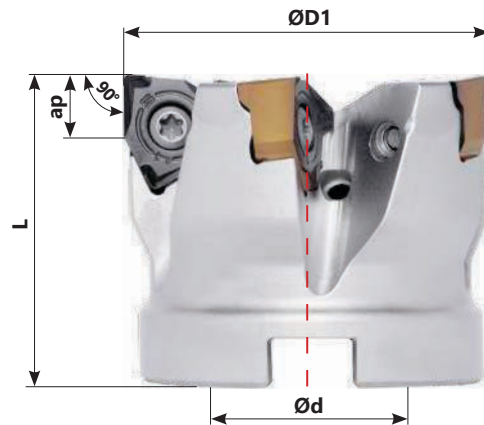

Bestellcode (Ordering Code)	Bezeichnung (Identification)	Platten (Inserts)		Maße (Dimensions) in mm			
		Typ (Type)	Anzahl (Number)	ØD1	Ød	L	ap
SW135-50	WNSW50-PFM-AM08-Z5-02	WN...08...	5	50	22	40	0,4-7,0
SW135-63	WNSW63-PFM-AM08-Z6-02	WN...08...	6	63	22	40	0,4-7,0
SW135-80	WNSW80-PFM-AM08-Z7-02	WN...08...	7	80	27	50	0,4-7,0
SW135-100	WNSW100-PFM-AM08-Z8-02	WN...08...	8	100	32	50	0,4-7,0
SW135-125	WNSW125-PFM-AM08-Z10-02	WN...08...	10	125	40	63	0,4-7,0
SW135-160	WNSW160-PFM-AM08-Z11-02	WN...08...	11	160	40	63	0,4-7,0

# FRÄSPLETTEN (MILLING INSERTS)

Bestellcode (Ordering Code)	Qualität (Grades)										
	P				M	K			N	S	H
	PVD				PVD	PVD			UNC	PVD	PVD
	SW11020	SW11030	SW11130	SW00040	SW11030	.	SW11020	SW11130	SW11140	SW00115	.



WNEU 040308-M	▲	▲	▲		▲		▲	▲				
---------------	---	---	---	--	---	--	---	---	--	--	--	--



WNEU 080608-MB	▲	▲	▲		▲		▲	▲				
----------------	---	---	---	--	---	--	---	---	--	--	--	--

## PLATTEN - TECHNISCHE DATEN (INSERTS - TECHNICAL DETAILS)

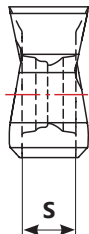
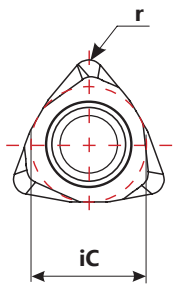

Bestellcode (Ordering Code)	Maße (Dimensions) in mm		
	iC	S	R
WNEU...04...	6,7	3,3	0,8
WNEU...MB...	12,5	6,56	0,8

# SCHNITTDATEN (CUTTING DATA)

Zu bearbeitendes Material (Material to be machined)		HB	Verschleißfestigkeit (Wear Resistance)				Vc (m/min)		Zähigkeit (Toughness)		
			SW11020	SW11030	SW11130	SW11140	SW11819	SW11314	SW00115	SW00025	SW00040
<b>P</b>	Unlegierter Stahl (Unalloyed Steel)	155-220	140-220	130-200	160-200	-	-	-	-	-	-
	Niedrig legierter Stahl (Low-Alloyed Steel)	220-280	140-200	130-180	130-180	-	-	-	-	-	-
	Hoch legierter Stahl (High-Alloyed Steel)	280-380	110-180	110-150	110-160	-	-	-	-	-	-
<b>M</b>	Rostfreier Stahl, ferritisch (Stainless Steels-ferritic)	200-330	-	90-130	80-120	-	-	-	-	-	-
	Rostfreier Stahl, austenitisch (Stainless Steel-austenitic)	200-330	-	60-110	50-100	-	-	-	-	-	-
<b>K</b>	Temperguss (Malleable Cast Iron)	130-230	170-220	-	150-200	-	-	-	-	-	-
	Grauguss (Grey Cast Iron)	180-245	150-200	-	130-170	-	-	-	-	-	-
	Gusseisen mit Kugelgraphit (Spheroidal Cast Iron)	160-250	100-170	-	120-160	-	-	-	-	-	-
<b>Vorschub/Zahn (feed/tooth) in mm</b>		-	0,1-0,3	0,1-0,3	0,1-0,3	-	-	-	-	-	-

Alle Schnittdaten dienen zur Orientierung  
(All cutting datas serve to orientation)

## ERSATZTEILE FÜR SW132-135 (SPARE PARTS FOR SW132-135)

Werkzeughdurchmesser (Tool Diameter) ØDc	Spannschraube (Insert Screw)	Torx Schlüssel (Torx Key)	Unterlegplatte / Unterlegscheibe (Shim / Washer)	Klemmschraube (Screw Clamp)
WNSW...AM...Ø20-Ø50...	 SW5258305	 BT08	 -	 -
WNSW...AM...Ø50-Ø160...	SW5408354	BT15	-	-

# ECKFRÄSEN SW108-111 (SHOULDER MILLING SW108-111)

## TOSW...WS...

Weldonschaft  
(Weldon Shank)



- Facing
- Helical Interpolation
- Slanted Shoulder & Chamfer
- Slotting

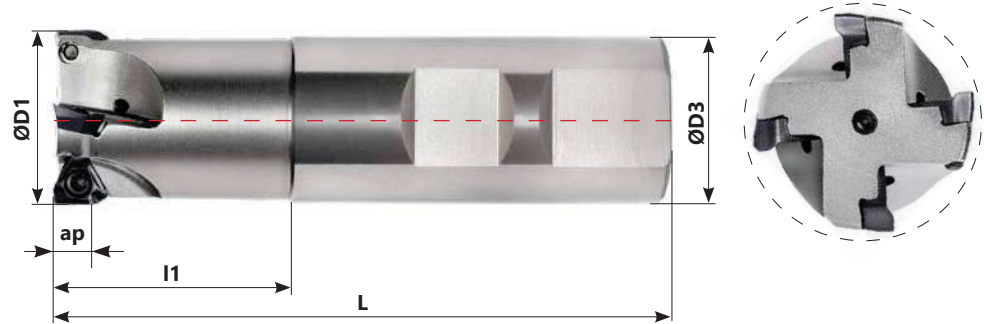

Bestellcode (Ordering Code)	Bezeichnung (Identification)	Platten (Inserts)		Maße (Dimensions) in mm				
		Typ (Type)	Anzahl (Number)	ØD1	ØD3	L	l1	ap
SW108-20	TOSW20-SM-WS07-Z3-01	TO...07...	3	20	20	77	25	0,8-5,0
SW108-25	TOSW25-SM-WS07-Z4-01	TO...07...	4	25	25	90	34	0,8-5,0
SW108-32	TOSW32-SM-WS07-Z5-01	TO...07...	5	32	32	102	40	0,8-5,0
SW110-32	TOSW32-SM-WS09-Z3-01	TO...09...	3	32	32	102	40	1,0-8,0

## TOSW...TC...

Einschraubmesserkopf  
(Threaded Coupling)



- Facing
- Helical Interpolation
- Slanted Shoulder & Chamfer
- Slotting

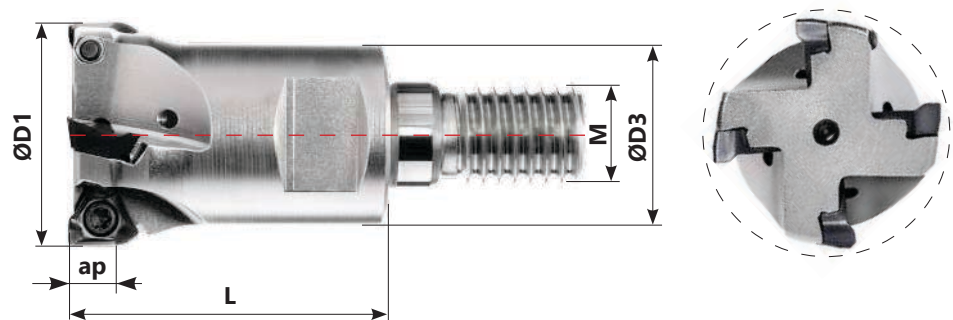

Bestellcode (Ordering Code)	Bezeichnung (Identification)	Platten (Inserts)		Maße (Dimensions) in mm				
		Typ (Type)	Anzahl (Number)	ØD1	ØD3	M	L	ap
SW109-20	TOSW20-SM-TC07-Z3-01	TO...07...	3	20	18	M10	33	0,8-5,0
SW109-25	TOSW25-SM-TC07-Z4-01	TO...07...	4	25	21	M12	36	0,8-5,0
SW109-32	TOSW32-SM-TC07-Z5-01	TO...07...	5	32	29	M16	17	0,8-5,0

# ECKFRÄSEN SW108-111 (SHOULDER MILLING SW108-111)

## TOSW...AM...

Aufsteckmesserkopf  
(Arbor Mounting)



Facing



Helical Interpolation



Slanted Shoulder & Chamfer



Slotting

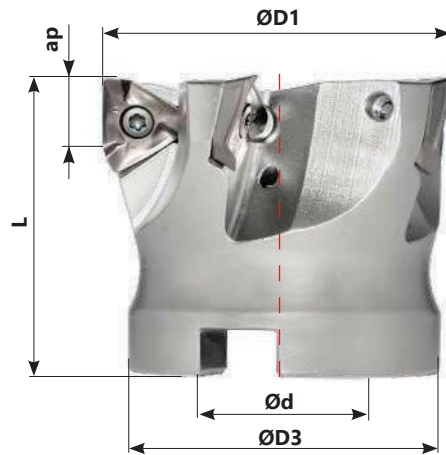

Bestellcode (Ordering Code)	Bezeichnung (Identification)	Platten (Inserts)		Maße (Dimensions) in mm				
		Typ (Type)	Anzahl (Number)	ØD1	ØD3	Ød	L	ap
SW111-40	TOSW40-SM-AM09-Z4-01	TO...09...	4	40	38	16	40	0,8-5,0
SW111-50	TOSW50-SM-AM09-Z5-01	TO...09...	5	50	43	22	40	0,8-5,0
SW111-63	TOSW63-SM-AM09-Z6-01	TO...09...	6	63	48	22	40	0,8-5,0

# FRÄSPLATTEN (MILLING INSERTS)

Bestellcode (Ordering Code)	Qualität (Grades)										
	P			M		K			N	S	H
	CVD	PVD		PVD	CVD	PVD			UNC	CVD	PVD
	SW22230	SW11235	.	SW11245	SW22535	.	.	.	SW00915	SW22535	.

	TOKX 070305PDER-HCM	▲	▲								
	TOKX 070308PDER-HCM	▲	▲								
	TOKX 070305PDER-SCM			▲	▲					▲	
	TOKX 070308PDER-SCM			▲	▲					▲	
	TOKX 09T308PDER-HCM	▲	▲								
	TOKX 09T312PDER-HCM	▲	▲								
	TOKX 09T316PDER-HCM	▲	▲								
	TOKX 09T308PDER-SCM			▲	▲					▲	
	TOKX 09T312PDER-SCM				▲					▲	
	TOKX 09T316PDER-SCM			▲	▲					▲	

## PLATTEN - TECHNISCHE DATEN (INSERTS - TECHNICAL DETAILS)

	Bestellcode (Ordering Code)	Maße (Dimensions) in mm			
		iC	S	I	R
	TO...070305...	5,9	3,15	1	0,5
	TO...070308...	5,9	3,15	1	0,8
	TO...09T308...	9,525	3,8	1,5	0,8
	TO...09T312...	9,525	3,8	1,5	1,2
	TO...09T316...	9,525	3,8	1,5	1,6

## ERSATZTEILE FÜR SW108-111 (SPARE PARTS FOR SW108-111)

Werkzeughdurchmesser (Tool Diameter) ØDc	Spannschraube (Insert Screw)	Torx Schlüssel (Torx Key)	Unterlegplatte / Unterlegscheibe (Shim / Washer)	Klemmschraube (Screw Clamp)
TO...07...	 SW5256008 M2.5 x 6.0	 T08	 -	 -
TO...09...	 SW5307308 M3.0 x 7.3	 T08	 -	 -
TO...09...	 SW5781826 M8.0 x 30.0	 T08	 -	 -

# SCHNITTDATEN (CUTTING DATA)

Zu bearbeitendes Material (Material to be machined)		HB	Vc (m/min)				Vorschub/Zahn (feed/tooth) (mm)		
			Verschleißfestigkeit (Wear Resistance)		Zähigkeit (Toughness)		Plattengröße (Insert size)	fz (mm)	ap (mm)
		SW22230	SW11235	SW11245	SW22535				
<b>P</b>	Unlegierter Stahl (Unalloyed Steel)	125-220	110-280	100-240	-	150-260	T07	0,08-0,15	0,8-5,0
	Niedrig legierter Stahl (Low-Alloyed Steel)	220-280	100-250	90-220	-	80-220			
	Hoch legierter Stahl (High-Alloyed Steel)	280-380	60-130	60-110	-	90-180	T09	0,08-0,20	1,0-8,0
<b>M</b>	Rostfreier Stahl, ferritisch (Stainless Steels-ferritic)	200-330	-	110-150	110-160	220-350	T07	0,08-0,13	0,8-5,0
	Rostfreier Stahl, austenitisch (Stainless Steel-austenitic)	200-330	-	110-150	110-170	150-240	T09	0,08-0,17	1,0-8,0
<b>K</b>	Temperguss (Malleable Cast Iron)	130-230	100-190	-	-	-	T07	0,07-0,16	0,8-5,0
	Grauguss (Grey Cast Iron)	180-245	100-310	-	-	-			
	Gusseisen mit Kugelgraphit (Spheroidal Cast Iron)	160-250	90-200	-	-	-	T09	0,08-0,22	1,0-8,0
<b>S</b>	Heat Resistant Super Alloys (Heat Resistant Super Alloys)	200-320	-	-	-	25-75	-	-	0,05-0,13

Alle Schnittdaten dienen zur Orientierung  
(All cutting datas serve to orientation)

## SCHRÄGEINTAUCHEN (RAMPING)

Schrägeintauchen (Ramping)			
Platte (Insert)	ØDc	Max Ramp α°	Max ap
TO...07...	20	1,4°	5,0
	25	1,2°	5,0
	32	0,8°	5,0
	20	1,4°	5,0
	25	1,2°	5,0
	32	0,8°	5,0
T...09....	32	1,1°	8,0
	40	0,8°	8,0
	50	0,5°	8,0
	63	0,5°	8,0

Während der Helixinterpolation oder des Schrägeintauchens darf der maximale Steigungswinkel α° nicht überschritten werden  
(During helical interpolation or ramping do not exceed max Pitch α°)

# ECKFRÄSEN SW112-114 (SHOULDER MILLING SW112-114)

## SDSW...WS...

Weldonschaft  
(Weldon Shank)



- Facing
- Helical Interpolation
- Slanted Shoulder & Chamfer
- Slotting

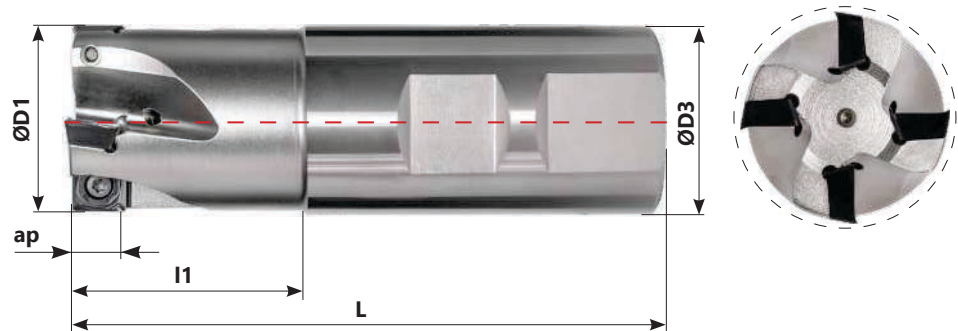

Bestellcode (Ordering Code)	Bezeichnung (Identification)	Platten (Inserts)		Maße (Dimensions) in mm				
		Typ (Type)	Anzahl (Number)	ØD1	ØD3	L	l1	ap
SW112-25	SDSW25-SM-WS09-Z3-01	SD...09...	3	25	25	88	32	0,1-4,0
SW112-32	SDSW32-SM-WS09-Z4-01	SD...09...	4	32	32	100	40	0,1-4,0
SW114-32	SDSW32-SM-WS12-Z3-01	SD...12...	3	32	32	100	40	0,5-10,0

## SDSW...AM...

Aufsteckmesserkopf  
(Arbor Mounting)



- Facing
- Helical Interpolation
- Slanted Shoulder & Chamfer
- Slotting

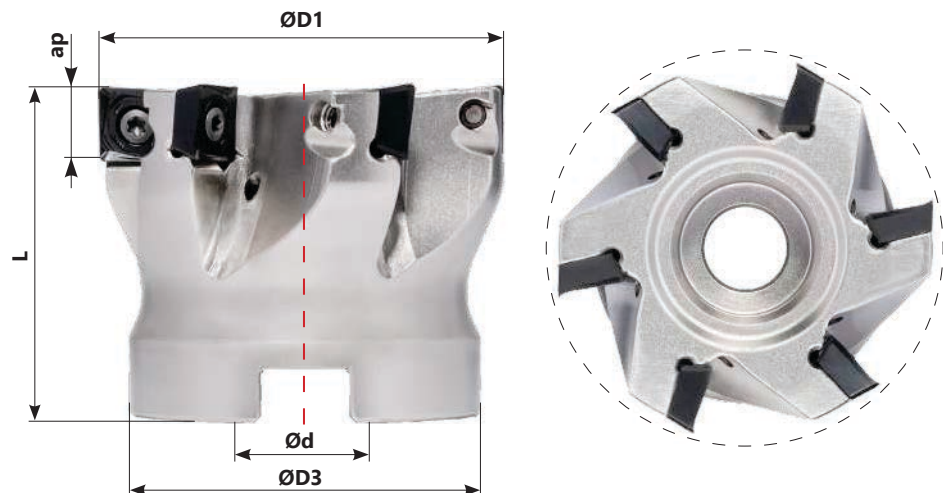

Bestellcode (Ordering Code)	Bezeichnung (Identification)	Platten (Inserts)		Maße (Dimensions) in mm				
		Typ (Type)	Anzahl (Number)	ØD1	ØD3	Ød	L	ap
SW113-40	SDSW40-SM-AM09-Z5-01	SD...09...	5	40	38	16	40	0,1-4,0
SW113-50	SDSW50-SM-AM09-Z6-01	SD...09...	6	50	43	22	40	0,1-4,0
SW113-63	SDSW63-SM-AM09-Z7-01	SD...09...	7	63	48	22	40	0,1-4,0
SW113-80	SDSW80-SM-AM09-Z9-01	SD...09...	9	80	58	27	50	0,1-4,0
SW114-40	SDSW40-SM-AM12-Z4-01	SD...12...	4	40	38	16	40	0,5-10,0
SW114-50	SDSW50-SM-AM12-Z5-01	SD...12...	5	50	43	22	40	0,5-10,0
SW114-63	SDSW63-SM-AM12-Z6-01	SD...12...	6	63	48	22	40	0,5-10,0
SW114-80	SDSW80-SM-AM12-Z7-01	SD...12...	7	80	58	27	50	0,5-10,0

# FRÄSPLATTEN (MILLING INSERTS)

Bestellcode (Ordering Code)	Qualität (Grades)										
	P			M		K			N	S	H
	CVD	PVD		PVD	CVD	CVD			UNC	CVD	PVD
	SW22230	SW11235	.	SW11245	SW22535	.	SW22415	.	SW00915	SW22540	.



SDKT 09T308SR-HCM	▲	▲									
SDKT 09T308SR-SCM				▲	▲						
SDKT 09T308SR-SCM										▲	



SDKT 09T308SR-CCM							▲				
SDHT 09T308FR-LMM								▲			



SDKT 120508SR-HCM	▲	▲									
SDKT 120508SR-SCM				▲	▲						
SDKT 120508SR-SCM										▲	



SDKT 120508SR-CCM							▲				
SDHT 120508FR-LMM								▲			

## PLATTEN - TECHNISCHE DATEN (INSERTS - TECHNICAL DETAILS)

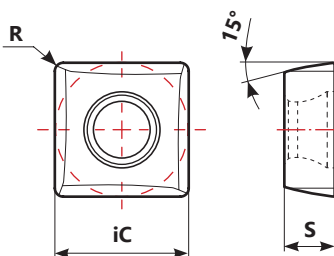

Bestellcode (Ordering Code)	Maße (Dimensions) in mm				
	iC	S	I	B	R
SDSW...WS/AM09...	9	3,97	9	-	0,8
SDSW...WS/AM12...	12,3	5	12,3	-	0,8

# SCHNITTDATEN (CUTTING DATA)

Zu bearbeitendes Material (Material to be machined)		HB	Verschleißfestigkeit (Wear Resistance)		Vc (m/min)	Zähigkeit (Toughness)		
			SW22230	SW11235	SW11245	SW22535	SW22415	SW00915
<b>P</b>	Unlegierter Stahl (Unalloyed Steel)	155-220	110-280	100-240	-	150-260	-	-
	Niedrig legierter Stahl (Low-Alloyed Steel)	220-280	100-250	90-220	-	80-220	-	-
	Hoch legierter Stahl (High-Alloyed Steel)	280-380	60-130	60-110	-	90-180	-	-
<b>M</b>	Rostfreier Stahl, ferritisch (Stainless Steels-ferritic)	200-330	-	110-150	110-160	220-350	-	-
	Rostfreier Stahl, austenitisch (Stainless Steel-austenitic)	200-330	-	110-150	110-170	150-240	-	-
<b>K</b>	Temperguss (Malleable Cast Iron)	130-230	100-190	-	-	-	200-320	120 - 200
	Grauguss (Grey Cast Iron)	180-245	100-310	-	-	-	100 - 190	90 - 160
	Gusseisen mit Kugelgraphit (Spheroidal Cast Iron)	160-250	90-200	-	-	-	100 - 180	90 - 170
<b>N</b>	Aluminium und NE-Metalle (Aluminium and Non Ferrous)	30-130	-	-	-	-	-	60 - 1500
<b>S</b>	Heat Resistant Super Alloys (Heat Resistant Super Alloys)	200-320	-	-	-	25-75	-	-
<b>Vorschub/Zahn (feed/tooth) in mm</b>		-	0,5-0,25	0,5-0,25	0,5-0,25	0,05-0,28	0,05-0,30	0,05-0,30

Alle Schnittdaten dienen zur Orientierung  
(All cutting datas serve to orientation)

# SCHRÄGEINTAUCHEN UND HELIXINTERPOLATION (RAMPING AND HELICAL INTERPOLATION)

Schrägeintauchen (Ramping)				Helixinterpolation (Helical Interpolation)		
Platte (Insert)	ØDc	Max Ramp $\alpha^\circ$	Max ap	ØDHmin	ØDHmax	Max Pitch/Rev.
SD...09...	25	4,4°	4	37	48	4,4
	32	2,2°	4	47	62	2,2
	40	0,75°	4	63	78	0,75
	50	0,5°	4	83	98	0,5
	63	0,35°	4	109	124	0,35
	80	0,25°	4	143	158	0,25
SD...12...	32	2,0°	10	41	62	2,0
	40	2,0°	10	57	78	2,0
	50	1,2°	10	77	98	1,2
	63	0,7°	10	103	124	0,7
	80	0,6°	10	137	158	0,6

Während der Helixinterpolation oder des Schrägeintauchens darf der maximale Steigungswinkel  $\alpha^\circ$  nicht überschritten werden  
(During helical interpolation or ramping do not exceed max Pitch  $\alpha^\circ$ )

## ERSATZTEILE FÜR SW112-114 (SPARE PARTS FOR SW112-114)

Werkzeughdurchmesser (Tool Diameter) ØDc	Spannschraube (Insert Screw)	Torx Schlüssel (Torx Key)	Unterlegplatte / Unterlegscheibe (Shim / Washer)	Klemmschraube (Screw Clamp)
SDSW...WS/AM09...	SW5255008 M2.5 x 5.0	T08	-	-
SDSW...AM09...Ø40	SW5818267 M8.0 x 30.0	-	-	-
SDSW...WS/AM12...	SW5401115 M4,0 x 11	T15	-	-
SDSW...WS12...Ø32	SW5123203 M4,0 x 8,5	T15	-	-
SDSW...WS/AM12...	SW5818267 M8,0 x 30,0	-	-	-

**APSWE...WS10...**

Weldonschaft  
 (Weldon Shank)

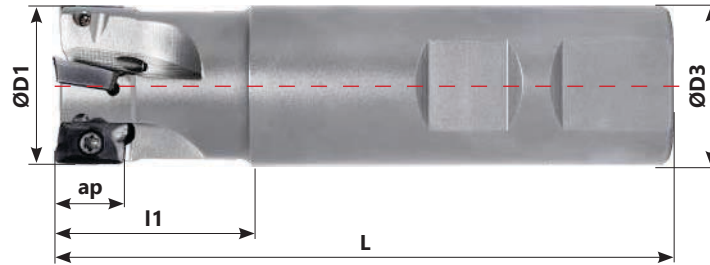

Bestellcode (Ordering Code)	Bezeichnung (Identification)	Platten (Inserts)		Maße (Dimensions) in mm				
		Typ (Type)	Anzahl (Number)	ØD1	ØD3	L	l1	ap
SW121-16-1	APSWE1685-SM-WS10-Z2-03	AP...10...	2	16	16	85	26	0,2-9,0
SW121-16-2	APSWE16150-SM-WS10-Z2-03	AP...10...	2	16	16	150	26	0,2-9,0
SW121-20-1	APSWE2090-SM-WS10-Z3-03	AP...10...	3	20	20	90	28	0,2-9,0
SW121-20-2	APSWE20150-SM-WS10-Z3-03	AP...10...	3	20	20	150	28	0,2-9,0
SW121-25-1	APSWE25150-SM-WS10-Z4-03	AP...10...	4	25	20	150	26	0,2-9,0
SW121-25-2	APSWE2590-SM-WS10-Z4-03	AP...10...	4	25	25	95	30	0,2-9,0

**APSWE...TC10...**

Einschraubmesserkopf  
 (Threaded Coupling)

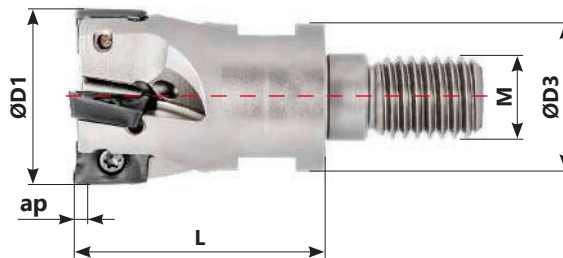

Bestellcode (Ordering Code)	Bezeichnung (Identification)	Platten (Inserts)		Maße (Dimensions) in mm				
		Typ (Type)	Anzahl (Number)	ØD1	ØD3	M	L	ap
SW122-16	APSWE16-SM-TC10-Z2-03	AP...10...	2	16	13	M8	25	0,2-9,0
SW122-20	APSWE20-SM-TC10-Z3-03	AP...10...	3	20	18	M10	30	0,2-9,0
SW122-25	APSWE25-SM-TC10-Z4-03	AP...10...	4	25	21	M12	35	0,2-9,0

# ECKFRÄSEN SW121-123 (SHOULDER MILLING SW121-123)

## APWE...AM10...

Aufsteckmesserkopf  
(Arbor Mounting)

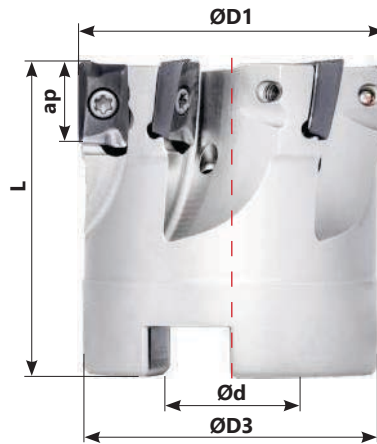

Bestellcode (Ordering Code)	Bezeichnung (Identification)	Platten (Inserts)		Maße (Dimensions) in mm				
		Typ (Type)	Anzahl (Number)	ØD1	ØD3	Ød	L	ap
SW123-40	APWE40-SM-AM10-Z6-03	AP...10...	6	40	39	22	40	0,2-9,0
SW123-50	APWE50-SM-AM10-Z7-03	AP...10...	7	50	40	22	40	0,2-9,0
SW123-63	APWE63-SM-AM10-Z8-03	AP...10...	8	63	48	22	40	0,2-9,0

# FRÄSPLATTEN (MILLING INSERTS)

Bestellcode (Ordering Code)	Qualität (Grades)										
	P					M	K			N	
	PVD					PVD		PVD			UNC
	SW11910	SW11920	SW11930	SW11125	SW11135	SW11920	SW11930	SW11920	SW11930	SW11740	SW00910



APKT 100305 PDER-X1		▲	▲				▲	▲	▲	
APKT 100305 PDSR-X1		▲	▲					▲	▲	



APKT 100308 PDER-X		▲	▲				▲	▲		
APKT 100308 PDSR-X		▲						▲		
APKT 100308 PDTR-X		▲	▲					▲	▲	
APKT 100312 PDER-X		▲	▲				▲	▲		
APKT 100312 PDSR-X		▲						▲		
APKT 100312 PDTR-X		▲	▲					▲	▲	



APET 100305 PDFR-LN										▲
---------------------	--	--	--	--	--	--	--	--	--	---

## PLATTEN - TECHNISCHE DATEN (INSERTS - TECHNICAL DETAILS)

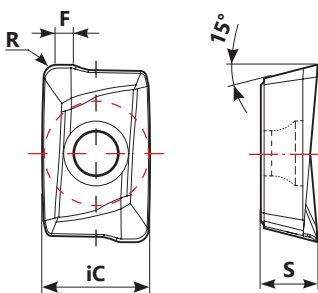

Bestellcode (Ordering Code)	Maße (Dimensions) in mm				
	iC	S	I	R	F
AP...100305...	6,70	3,50	10,0	0,50	1,20
AP...100308...	6,70	3,50	10,0	0,80	0,90
AP...100312...	6,70	3,50	10,0	1,20	-

# SCHNITTDATEN (CUTTING DATA)

Zu bearbeitendes Material (Material to be machined)		HB	Verschleißfestigkeit (Wear Resistance)				Vc (m/min)	Zähigkeit (Toughness)	Vorschub/Zahn (feed/tooth) in mm		
			SW11920	SW11930	SW11740	SW00910			APKT 10... PDER-X/X1	APKT 10... PDS(T)R-X/X1	APET 10... PDFR-LN
<b>P</b>	Unlegierter Stahl (Unalloyed Steel)	125-220	150-230	150-180		-		0,07-0,15	0,10-0,25	-	
	Niedrig legierter Stahl (Low-Alloyed Steel)	220-280	140-220	140-170		-		0,07-0,10	0,10-0,20	-	
	Hoch legierter Stahl (High-Alloyed Steel)	280-380	130-180	120-150		-		0,07-0,10	0,10-0,20	-	
<b>M</b>	Rostfreier Stahl, ferritisch (Stainless Steels-ferritic)	200-330	-	90-150		-		0,07-0,10	0,10-0,20	-	
	Rostfreier Stahl, austenitisch (Stainless Steel-austenitic)	200-330	-	80-130		-		0,07-0,10	0,10-0,20	-	
<b>K</b>	Temperguss (Malleable Cast Iron)	130-230	150-280	80-230		-		0,07-0,15	0,10-0,25	-	
	Grauguss (Grey Cast Iron)	180-245	130-230	120-225		-		0,07-0,15	0,10-0,25	-	
	Gusseisen mit Kugelgraphit (Spheroidal Cast Iron)	160-250	80-190	80-180		-		-	0,10-0,20	-	
<b>N</b>	Aluminium und NE-Metalle (Aluminium and Non Ferrous)	30-130	-	-		350-1400		-	-	0,07-0,20	
<b>S</b>	Heat Resistant Super Alloys (Heat Resistant Super Alloys)	200-320	-	-	30-70	-		0,10-0,20	-	-	

Operation (Operation)	ae	Vc & fz	ap (mm)
<b>Slotting</b> (Schlitzfräsen)	100%	<20%	3,0-4,0
<b>Eckbearbeitung</b> (Shouldering)	<50%	>8%	5,0-6,0
	≤25%	>12%	7,0-8,0

Alle Schnittdaten dienen zur Orientierung  
(All cutting datas serve to orientation)

# SCHRÄGEINTAUCHEN UND HELIXINTERPOLATION (RAMPING AND HELICAL INTERPOLATION)

Schrägeintauchen (Ramping)			Helixinterpolation (Helical Interpolation)		
			Sackloch; sauberer Grund (Blind hole; Flat bottom)		
ØDc	Max Ramp $\alpha^\circ$	Max ap	ØDHmin	ØDHmax	Max Pitch/Rev
16	1,3°	9,0	29,2	31,0	1,1
20	0,9°	9,0	37,2	39,0	0,9
25	0,6°	9,0	47,2	49,0	0,8
40	0,4°	9,0	77,2	79,0	0,9
50	0,25°	9,0	97,2	99,0	0,7
63	0,2°	9,0	123,2	125,0	0,7

Während der Helixinterpolation oder des Schrägeintauchens darf der maximale Steigungswinkel  $\alpha^\circ$  nicht überschritten werden  
(During helical interpolation or ramping do not exceed max Pitch  $\alpha^\circ$ )

# ZUBEHÖR FÜR SW121-123 (EQUIPMENT FOR SW121-123)

## ERSATZTEILE (SPARE PARTS)

Werkzeugdurchmesser (Tool Diameter) ØDc	Spannschraube (Insert Screw)	Torx Schlüssel (Torx Key)	Unterlegplatte / Unterlegscheibe (Shim / Washer)	Klemmschraube (Screw Clamp)
APSW...Ø16-Ø25	 SW5250503	 XT08	 -	 -
APSW...Ø40-Ø63	SW5250503	XT08	-	-

# ECKFRÄSEN SW124-125 (SHOULDER MILLING SW124-125)

## APWE...WS16...

Weldonschaft  
(Weldon Shank)

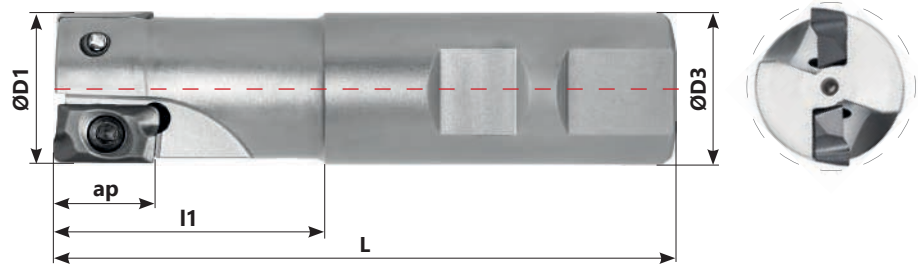

Bestellcode (Ordering Code)	Bezeichnung (Identification)	Platten (Inserts)		Maße (Dimensions) in mm				
		Typ (Type)	Anzahl (Number)	ØD1	ØD3	L	l1	ap
SW124-25-1	APWE25100-SM-WS16-Z2-03	AP...16...	2	25	25	100	44	0,3-14,5
SW124-25-2	APWE25200-SM-WS16-Z2-03	AP...16...	2	25	25	200	60	0,3-14,5
SW124-32-1	APWE32110-SM-WS16-Z3-03	AP...16...	3	32	32	110	50	0,3-14,5
SW124-32-2	APWE32200-SM-WS16-Z3-03	AP...16...	3	32	32	200	60	0,3-14,5
SW124-40-1	APWE40115-SM-WS16-Z4-03	AP...16...	4	40	32	115	40	0,3-14,5
SW124-40-2	APWE40200-SM-WS16-Z4-03	AP...16...	4	40	32	200	40	0,3-14,5



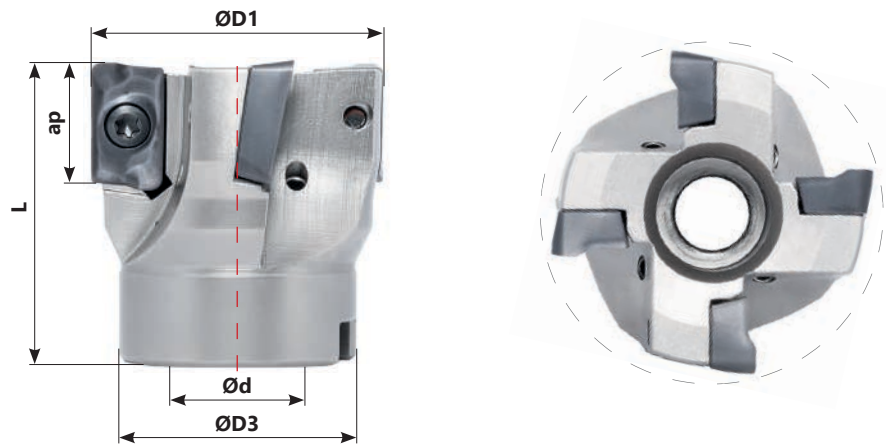

## APWE...AM16...

Aufsteckmesserkopf  
(Arbor Mounting)



Bestellcode (Ordering Code)	Bezeichnung (Identification)	Platten (Inserts)		Maße (Dimensions) in mm				
		Typ (Type)	Anzahl (Number)	ØD1	ØD3	Ød	L	ap
SW125-40	APWE40-SM-AM16-Z4-03	AP...16...	4	40	32	16	40	0,3-14,5
SW125-50	APWE50-SM-AM16-Z5-03	AP...16...	5	50	42	22	40	0,3-14,5
SW125-63	APWE63-SM-AM16-Z6-03	AP...16...	6	63	52	22	40	0,3-14,5
SW125-80	APWE80-SM-AM16-Z7-03	AP...16...	7	80	60	27	50	0,3-14,5
SW125-100	APWE100-SM-AM16-Z8-03	AP...16...	8	100	80	32	50	0,3-14,5
SW125-125	APWE125-SM-AM16-Z9-03	AP...16...	9	125	90	40	63	0,3-14,5

# FRÄSPLATTEN (MILLING INSERTS)

Bestellcode (Ordering Code)	Qualität (Grades)											
	P				M		K				N	S
	PVD				PVD		PVD				UNC	PVD
	SW11920	SW12920	SW11930	SW12930	SW11930	SW12930	SW11920	SW12920	SW11930	SW12930	SW00910	SW11740
 APKT 160408 PDER-X1	▲		▲		▲		▲		▲			
APKT 160408 PDSR-X1	▲		▲		▲		▲		▲			
 APKT 160408 PDER-X2		▲		▲		▲		▲		▲		
APKT 160408 PDSR-X2		▲		▲		▲		▲		▲		
 APKT 160416 PDER-X	▲						▲					
APKT 160416 PDSR-X	▲		▲				▲		▲			
APKT 160432 PDER-X	▲						▲					
APKT 160432 PDSR-X	▲						▲					
 APHT 1604 PDFR-LN											▲	
 APKT 160408 PDFR-LN											▲	

## PLATTEN - TECHNISCHE DATEN (INSERTS - TECHNICAL DETAILS)

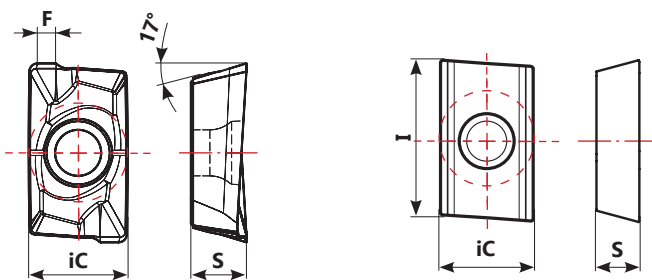

Bestellcode (Ordering Code)	Maße (Dimensions) in mm				
	iC	S	I	F	R
AP...160408...	9,45	5,35	16	1,8	0,8
AP...160416...	9,45	5,35	16	1,2	1,6
AP...160432...	9,45	5,35	16	-	3,2
AP...1604...	9,45	5,35	16	1,74	-

# SCHNITTDATEN (CUTTING DATA)

Zu bearbeitendes Material (Material to be machined)		HB	Verschleißfestigkeit Vc Zähigkeit (Wear Resistance) (m/min) (Toughness)			Vorschub/Zahn (feed/tooth) in mm		
			SW11920	SW11930	SW00910	APKT 16... PDER-X/X2	APKT 16... PDS(T)R-X/X2	AP...T 16... PDFR-LN
<b>P</b>	Unlegierter Stahl (Unalloyed Steel)	125-220	150-230	150-180	-	0,07-0,15	0,10-0,25	-
	Niedrig legierter Stahl (Low-Alloyed Steel)	220-280	140-220	140-170	-	0,07-0,10	0,10-0,20	-
	Hoch legierter Stahl (High-Alloyed Steel)	280-380	130-180	120-150	-	0,07-0,10	0,10-0,20	-
<b>M</b>	Rostfreier Stahl, ferritisch (Stainless Steels-ferritic)	200-330	-	90-150	-	0,07-0,10	0,10-0,20	-
	Rostfreier Stahl, austenitisch (Stainless Steel-austenitic)	200-330	-	80-130	-	0,07-0,10	0,10-0,20	-
<b>K</b>	Temperguss (Malleable Cast Iron)	130-230	150-280	80-230	-	0,07-0,15	0,10-0,25	-
	Grauguss (Grey Cast Iron)	180-245	130-230	120-225	-	0,07-0,15	0,10-0,25	-
	Gusseisen mit Kugelgraphit (Spheroidal Cast Iron)	160-250	80-190	80-180	-	-	0,10-0,20	-
<b>N</b>	Aluminium und NE-Metalle (Aluminium and Non Ferrous)	30-130	-	-	350-1400	-	-	0,07-0,20
<b>S</b>	Heat Resistant Super Alloys (Heat Resistant Super Alloys)	200-320	-	-	-	0,10-0,20	-	-

Alle Schnittdaten dienen zur Orientierung  
(All cutting datas serve to orientation)

# ZUBEHÖR FÜR SW 124-125 (EQUIPMENT FOR SW124-125)

Schrägeintauchen (Ramping)			Helixinterpolation (Helical Interpolation)		
ØDc	Max Ramp $\alpha^\circ$	Max ap	ØDHmin	ØDHmax	Max Pitch/Rev
25	3°	14,5	46,1	48,4	3,9
32	2°	14,5	60,1	62,4	3,3
40	1,5°	14,5	76,1	78,4	3,2
50	1,1°	14,5	96,1	98,4	2,9
63	0,85°	14,5	122,1	124,4	2,9
80	0,64°	14,5	156,1	158,4	2,7
100	0,5°	14,5	196,1	198,4	2,7
125	0,38°	14,5	246,1	248,4	2,6





Während der Helixinterpolation oder des Schrägeintauchens darf der maximale Steigungswinkel  $\alpha^\circ$  nicht überschritten werden  
(During helical interpolation or ramping do not exceed max Pitch  $\alpha^\circ$ )

## ERSATZTEILE FÜR SW124-125 (SPARE PARTS FOR SW124-125)

Werkzeugdurchmesser (Tool Diameter) ØDc	Spannschraube (Insert Screw)	Torx Schlüssel (Torx Key)	Unterlegplatte / Unterlegscheibe (Shim / Washer)	Klemmschraube (Screw Clamp)
APSW...WS...Ø25-Ø40	SW5400900	XT15	-	-
APSW...AM...Ø40-Ø80	SW5400900	XT15	-	-
APSW...AM...Ø100-Ø125	SW5400900	XT15	-	-

## LNKU...

**Aufsteckmesserkopf  
(Arbor Mounting)**

-  Facing
-  Helical Interpolation
-  Shouldering
-  Slotting

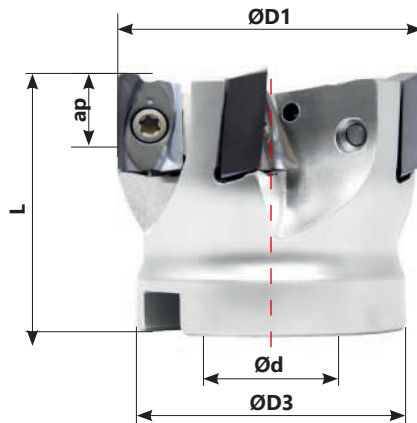

Bestellcode (Ordering Code)	Bezeichnung (Identification)	Platten (Inserts)		Maße (Dimensions) in mm				
		Typ (Type)	Anzahl (Number)	D1	D3	d	L	ap
SW142-50	LNSW50-SM-AM12-Z5-01	L... 12...	5	50	43	22	40 / 40.44*	2.0 - 12

\*mit LOKU Platte (with LOKU insert)

# FRÄSPLATTEN (MILLING INSERTS)

Bestellcode (Ordering Code)	Qualität (Grades)									
	P		M		K			N	S	H
	CVD	PVD	PVD	CVD	PVD			UNC	CVD	PVD
	SW22230	SW11235	SW11245	SW222535	.	.	.	SW00915	SW222535	.



LNKU 120608-HCM	▲	▲								
LNKU 120608-SCM			▲							



LOKU 120608-SCM			▲							
-----------------	--	--	---	--	--	--	--	--	--	--

## PLATTEN - TECHNISCHE DATEN (INSERTS - TECHNICAL DETAILS)

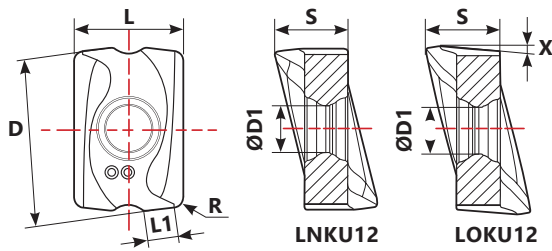

Bestellcode (Ordering Code)	Maße (Dimensions) in mm						
	D	D1	S	L	L1	R	X
LKNU... 12...	15.27	4.4	6.78	10	2.84	0.8	-
LOKU... 12...	15.86	4.4	6.87	10	2.57	0.8	5

# SCHNITTDATEN (CUTTING DATA)

Zu bearbeitendes Material (Material to be machined)	HB	Vc (m/min)						Vorschub/Zahn (feed/tooth) in mm
		Verschleißfestigkeit (Wear Resistance)			Zähigkeit (Toughness)			
		SW22230	SW11235	SW12240	SW22535	SW22415	SW00915	
<b>P</b>	Unlegierter Stahl (Unalloyed Steel)	155-220	150-220	150-220	-	-	-	0,05-0,3
	Niedrig legierter Stahl (Low-Alloyed Steel)	220-280	100-200	100-200	-	-	-	
	Hoch legierter Stahl (High-Alloyed Steel)	280-380	60-150	60-150	-	-	-	
<b>M</b>	Rostfreier Stahl, ferritisch (Stainless Steels-Ferritic)	200-330	-	-	100-200	-	-	0,05-0,3
	Rostfreier Stahl, austenitisch (Stainless Steel-Austenitic)	200-330	-	-	60-150	-	-	

Alle Schnittdaten dienen zur Orientierung (All cutting datas serve to orientation)

## SCHNITTDATEN LNKU/LOKU (CUTTING DATA LNKU/LOKU)

Startparameter (Starting parameters)

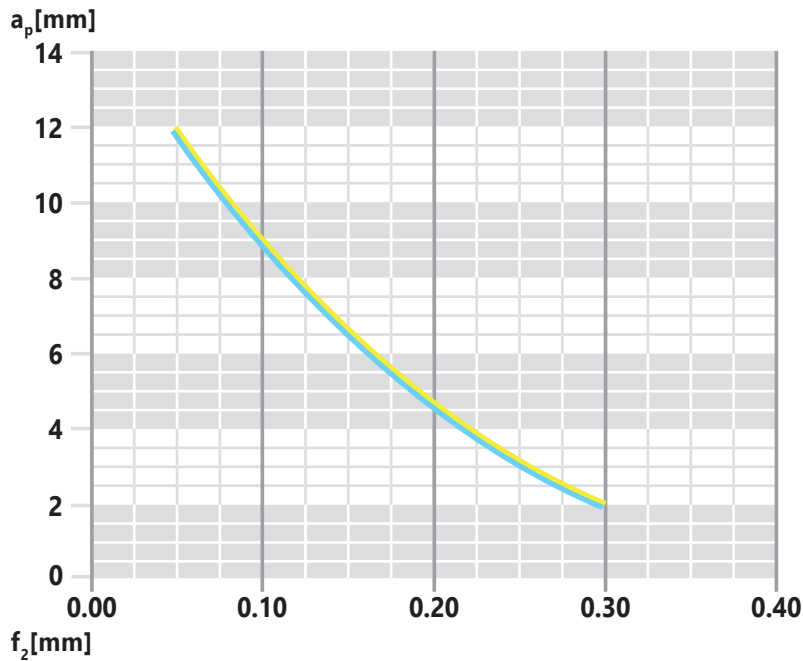

**ERSATZTEILE (SPARE PARTS)**

Werkzeugdurchmesser (Tool Diameter) ØDc	Spannschraube (Insert Screw)	Torx Schlüssel (Torx Key)	Unterlegplatte / Unterlegscheibe (Shim / Washer)	Klemmschraube (Screw Clamp)
LNSW...	 SW11042274	 -	 -	 -
LNSW...	-	-	-	SW11040298

# SCHNITTDATENBERECHNUNG (CUTTING DATA CALCULATION)

## FORMELN (FORMULAS)

Drehzahl (UPM)  
(Spindle Speed) (RPM)

$$n = \frac{V_c \cdot 1000}{\pi \cdot D_c}$$

Schnittgeschwindigkeit  
(Cutting Speed) (m/min)

$$V_c = \frac{n \cdot \pi \cdot D_c}{1000}$$

Vorschubgeschwindigkeit  
(Feed Speed) (mm/min)

$$V_f = n \cdot Z_n \cdot f_z$$

Vorschub pro Zahn (mm/Zahn)  
(Feed per Tooth) (mm/tooth)

$$f_z = \frac{V_f}{n \cdot Z_n}$$

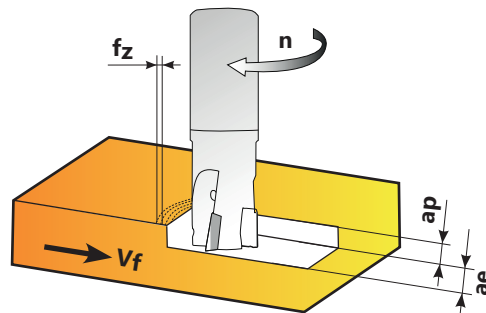

Vorschub pro Umdrehung (mm/U)  
(Feed per Revolution) (mm/rev)

$$f = \frac{V_f}{n \cdot Z_n}$$

Materialabtragrate  
(Metal removal Rate) (cm<sup>3</sup>/min)

$$Q = \frac{a_e \cdot a_p \cdot V_f}{1000}$$

## SCHNITTGESCHWINDIGKEIT UND DREHZAHL FÜR DAS KOPIERFRÄSEN (CUTTING SPEED AND SPINDLE SPEED FOR COPYING)

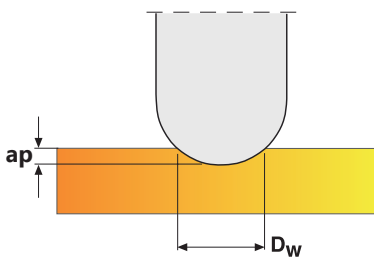

$$V_c = \frac{n \cdot \pi \cdot D_w}{1000} \quad \text{m/min}$$

$$n = \frac{V_c \cdot 1000}{\pi \cdot D_w} \quad \text{UPM (RPM)}$$

$$D_w = 2 \cdot \sqrt{a_p (D_c - a_p)} \quad \text{mm}$$

**ae** - Schnittbreite / radiale Schnitttiefe  
(Width of cut) / (radial depth of cut) (mm)

**ap** - Schnitttiefe / axiale Schnitttiefe  
(Depth of cut) / (axial depth of cut) (mm)

**Dc** - Werkzeugdurchmesser  
(Cutter Diameter) (mm)

**f** - Vorschub pro Umdrehung (mm/U)  
(Feed per Revolution) (mm/rev)

**fz** - Vorschub pro Zahn (mm/Zahn)  
(Feed per Tooth) (mm/tooth)

**n** - Drehzahl (UPM)  
(Spindle Speed) (RPM)

**Q** - Materialabtragrate  
(Material removal Rate) (cm<sup>3</sup>/min)

**Vc** - Schnittgeschwindigkeit  
(Cutting Speed) (m/min)

**Vf** - Vorschubgeschwindigkeit  
(Feed Speed) (mm/min)

**Zn** - Anzahl der Zähne  
(Number of teeth)

# LEISTUNGSBEDARFSBERECHNUNG (POWER REQUIREMENT CALCULATION)

## BERECHNUNG DES LEISTUNGSBEDARFS (CALCULATING THE POWER DEMAND)

$$P_c = \frac{a_p \cdot a_e \cdot v_f}{60\,000\,000 \cdot \eta} \cdot k_c$$

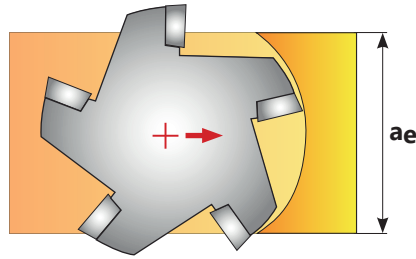

- P<sub>c</sub>** - Leistung (Power) (kW)
- a<sub>p</sub>** - Schnitttiefe (Depth of cut) (mm)
- a<sub>e</sub>** - Schnittbreite (Width of cut) (mm)
- v<sub>f</sub>** - Vorschubgeschwindigkeit (Feed speed) (mm/min)
- η** - Effizienz (Efficiency)
- k<sub>c</sub>** - Schnittkraft (Cutting force) (N/mm<sup>2</sup>)

## BERECHNUNG DER MITTLEREN SPANDICKE (h<sub>m</sub>) CALCULATING AVERAGE CHIP THICKNESS (h<sub>m</sub>)

$$h_m = \frac{360 \cdot f_z \cdot a_e \cdot \sin k_r}{\pi \cdot D_c \cdot \omega_e}$$

- h<sub>m</sub>** - Durchschnittliche Spandicke (Average chip thickness) (mm)
- f<sub>z</sub>** - Vorschub pro Zahn (Feed per tooth) (mm/tooth)
- D<sub>c</sub>** - Werkzeugdurchmesser (Cutter diameter) (mm)
- ω<sub>e</sub>** - Eingriffswinkel (Engagement angle) (mm/min)
- k<sub>r</sub>** - Steigungswinkel (Lead angle)

## EINGRIFFSWINKEL (ENGAGEMENT ANGLE)

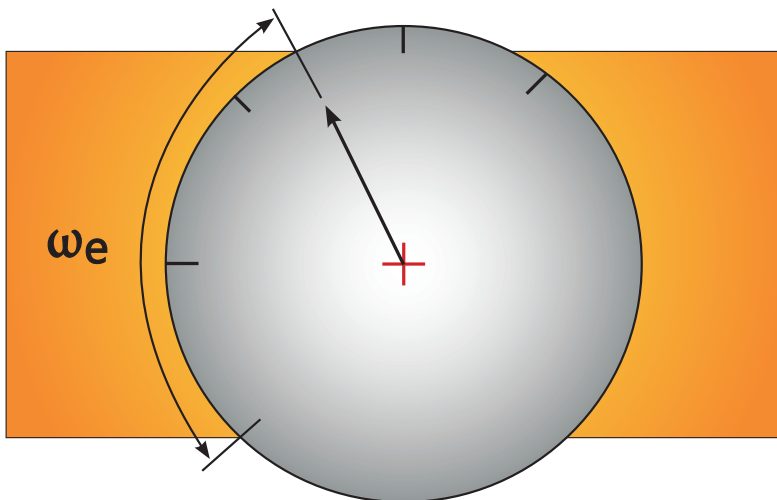

Eingriffsbreite (Engagement) a <sub>e</sub> / D <sub>c</sub>	Eingriffswinkel (Engagement angle) ω <sub>e</sub>
5%	26°
10%	37°
25%	60°
70%	89°
100%	180°

## **FLANKENVERSCHLEISS** **(EDGE WEAR)**

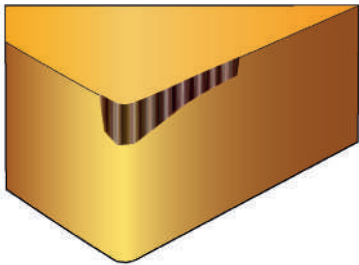

- Vorschub erhöhen  
*(Increase feed rate)*
- Schnittgeschwindigkeit reduzieren  
*(Reduce cutting speed)*
- Verschleißfestere Sorte wählen  
*(Use more wear resistant grade)*
- Kühlung optimieren  
*(Apply coated grade)*

## **PLASTISCHE DEFORMATION** **(HEAT DEFORMATION/UPSET)**

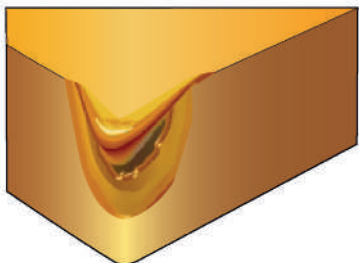

- Schnittgeschwindigkeit reduzieren  
*(Reduce cutting speed)*
- Vorschub reduzieren  
*(Reduce feed)*
- Schnitttiefe reduzieren  
*(Reduce depth of cut)*
- Sorte mit höherer Warmfestigkeit wählen  
*(Use grade with higher hot hardness)*

## **AUSBRÜCHE** **(THERMAL CRACKING)**

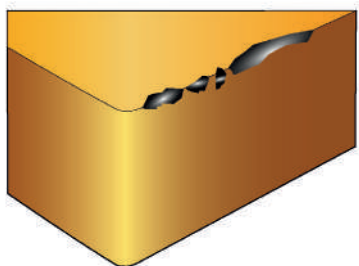

- Kühlung optimieren  
*(Properly apply coolant)*
- Schnittgeschwindigkeit erhöhen  
*(Increase cutting speed)*
- Vorschub reduzieren  
*(Reduce feed)*
- Einen zäheren Schneidstoff verwenden  
*(Use a tougher cutting material)*

## **KOLKVERSCHLEISS** **(CRATER)**

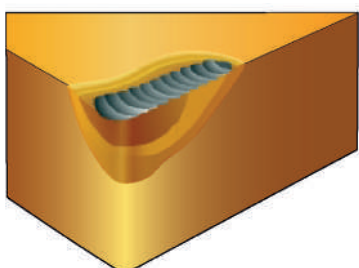

- Verschleißfestere Schneidstoffsorte wählen  
*(Select a more wear resistant grade)*
- Schnittgeschwindigkeit reduzieren  
*(Reduce cutting speed)*
- Schmalere Fase einsetzen oder den Vorschub auf den entsprechenden Bereich der Fase erhöhen  
*(Use a narrower chamfer or move the feed to the appropriate area of the machine increase chamfer)*

## KAMMRISSE (COMB CRACKS)

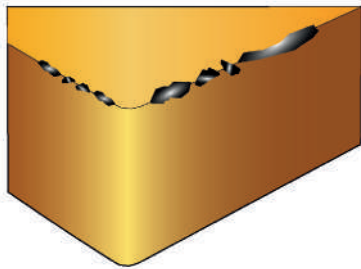

- Schnittgeschwindigkeit reduzieren  
(Reduce cutting speed)
- Reduzierung des Zahnvorschubs  
(Reduction of tooth feed)
- Kühlmittel abstellen  
(Turn off the coolant)
- Beschichtete Schneidstoffe verwenden, die für Nassbearbeitung geeignet sind  
(Use coated cutting materials that are suitable for wet machining)

## KERB- ODER OXIDATIONSVERSCHLEISS (DEPTH-OF-CUT NOTCHING)

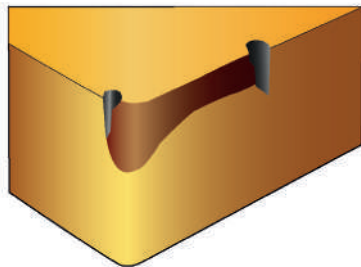

- Fräser mit kleinerem Einstellwinkel wählen  
(Select a cutter with a smaller setting angle)
- Ecken vorbereiten  
(Consider edge preparation)
- Verschleißfestere Schneidstoffsorte wählen  
(Select a more wear resistant grade)
- Reduzierung des Zahnvorschubs  
(Reduction of tooth feed)

## AUFBAUSCHNEIDE (BUILT-UP EDGE)

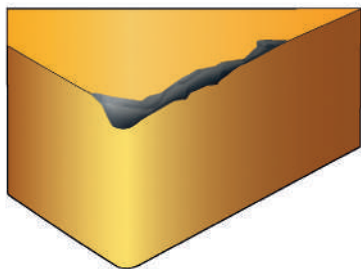





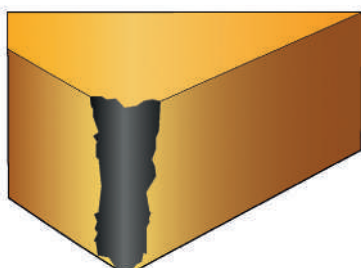





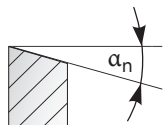
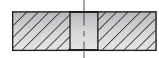

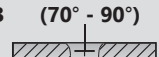

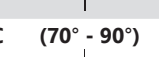





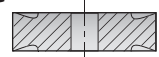











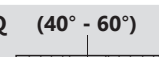

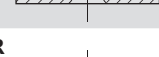

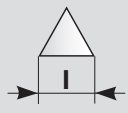

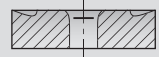
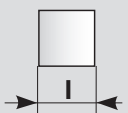

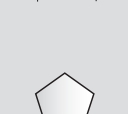
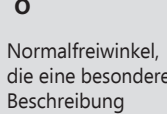
- Schnittgeschwindigkeit erhöhen  
(Increase cutting speed)
- Vorschub erhöhen  
(Increase feed rate)
- Kühlung optimieren  
(Utilize coolant)
- Scharfe Schneiden, PVD-beschichtete Schneidplatten mit positivem Spanwinkel oder polierte Schneidplatten verwenden  
(Use sharp edges, PVD-coated inserts with positive rake angle or polished inserts)

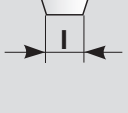
## SCHNEIDENBRUCH (CATASTROPHIC BREAKAGE)

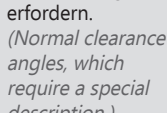

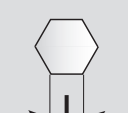
- Stärkere Beschichtung / Geometry wählen  
(Select stronger grade / geometry)
- Vorschub reduzieren  
(Reduce feed rate)
- Schnitttiefe reduzieren  
(Reduce depth of cut)
- Plattensitz und generelle Stabilität des Werkzeugs überprüfen  
(Check rigidity of system)

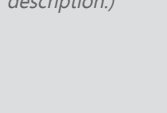
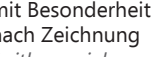
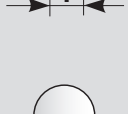
# ISO BEZEICHNUNGSSYSTEM (ISO DESIGNATION SYSTEM)

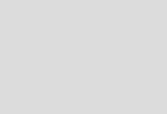
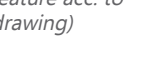
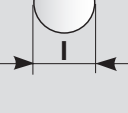
<b>A</b> <b>Grundform</b> <i>(Insert shape)</i>	<b>P</b> <b>Freiwinkel</b> <i>(Clearance angle)</i>	<b>K</b> <b>Toleranzen</b> <i>(Tolerances)</i>	<b>T</b> <b>Spanformer, Befestigung</b> <i>(Chip breaker, clamp type)</i>	<b>16</b> <b>Schneidenlänge</b> <i>(Cutting edge length)</i>						
<b>A</b>  85°		<table border="1"> <thead> <tr> <th></th> <th>m</th> <th>s</th> <th>d</th> </tr> </thead> </table>		m	s	d	<b>A</b> 	<table border="1"> <thead> <tr> <th></th> <th>I</th> </tr> </thead> </table>		I
		m	s	d						
		I								
<b>B</b>  82°		<table border="1"> <tr> <td><b>A</b></td> <td>± 0,005</td> <td>± 0,025</td> <td>± 0,025</td> </tr> </table>	<b>A</b>	± 0,005	± 0,025	± 0,025	<b>B (70° - 90°)</b> 	<table border="1"> <tr> <td><b>06</b></td> <td>6,350</td> </tr> </table>	<b>06</b>	6,350
<b>A</b>		± 0,005	± 0,025	± 0,025						
<b>06</b>	6,350									
<b>C</b>  80°	<table border="1"> <tr> <td><b>C</b></td> <td>± 0,013</td> <td>± 0,025</td> <td>± 0,025</td> </tr> </table>	<b>C</b>	± 0,013	± 0,025	± 0,025	<b>C (70° - 90°)</b> 	<table border="1"> <tr> <td><b>07</b></td> <td>7,938</td> </tr> </table>	<b>07</b>	7,938	
<b>C</b>	± 0,013	± 0,025	± 0,025							
<b>07</b>	7,938									
<b>D</b>  55°	$\alpha_n$	<table border="1"> <tr> <td><b>E</b></td> <td>± 0,025</td> <td>± 0,025</td> <td>± 0,025</td> </tr> </table>	<b>E</b>	± 0,025	± 0,025	± 0,025	<b>F</b> 	<table border="1"> <tr> <td><b>09</b></td> <td>9,525</td> </tr> </table>	<b>09</b>	9,525
<b>E</b>	± 0,025	± 0,025	± 0,025							
<b>09</b>	9,525									
<b>E</b>  75°	<b>A</b> 3°	<table border="1"> <tr> <td><b>F</b></td> <td>± 0,005</td> <td>± 0,025</td> <td>± 0,013</td> </tr> </table>	<b>F</b>	± 0,005	± 0,025	± 0,013	<b>G</b> 	<table border="1"> <tr> <td><b>11</b></td> <td>11,000</td> </tr> </table>	<b>11</b>	11,000
<b>F</b>	± 0,005	± 0,025	± 0,013							
<b>11</b>	11,000									
<b>H</b>  120°	<b>B</b> 5°	<table border="1"> <tr> <td><b>G</b></td> <td>± 0,025</td> <td>± 0,13</td> <td>± 0,025</td> </tr> </table>	<b>G</b>	± 0,025	± 0,13	± 0,025	<b>H (70° - 90°)</b> 	<table border="1"> <tr> <td><b>12</b></td> <td>12,700</td> </tr> </table>	<b>12</b>	12,700
<b>G</b>	± 0,025	± 0,13	± 0,025							
<b>12</b>	12,700									
<b>K</b>  55°	<b>C</b> 7°	<table border="1"> <tr> <td><b>H</b></td> <td>± 0,013</td> <td>± 0,025</td> <td>± 0,013</td> </tr> </table>	<b>H</b>	± 0,013	± 0,025	± 0,013	<b>J (70° - 90°)</b> 	<table border="1"> <tr> <td><b>15</b></td> <td>15,875</td> </tr> </table>	<b>15</b>	15,875
<b>H</b>	± 0,013	± 0,025	± 0,013							
<b>15</b>	15,875									
<b>L</b>  90°	<b>D</b> 15°	<table border="1"> <tr> <td><b>J</b></td> <td>± 0,005</td> <td>± 0,025</td> <td>siehe see Tab. 4</td> </tr> </table>	<b>J</b>	± 0,005	± 0,025	siehe see Tab. 4	<b>M</b> 	<table border="1"> <tr> <td><b>16</b></td> <td>16,500</td> </tr> </table>	<b>16</b>	16,500
<b>J</b>	± 0,005	± 0,025	siehe see Tab. 4							
<b>16</b>	16,500									
<b>M</b>  86°	<b>E</b> 20°	<table border="1"> <tr> <td><b>K</b></td> <td>± 0,013</td> <td>± 0,025</td> <td>siehe see Tab. 4</td> </tr> </table>	<b>K</b>	± 0,013	± 0,025	siehe see Tab. 4	<b>N</b> 	<table border="1"> <tr> <td><b>19</b></td> <td>19,050</td> </tr> </table>	<b>19</b>	19,050
<b>K</b>	± 0,013	± 0,025	siehe see Tab. 4							
<b>19</b>	19,050									
<b>O</b>  135°	<b>F</b> 25°	<table border="1"> <tr> <td><b>L</b></td> <td>± 0,025</td> <td>± 0,025</td> <td>siehe see Tab. 4</td> </tr> </table>	<b>L</b>	± 0,025	± 0,025	siehe see Tab. 4	<b>Q (40° - 60°)</b> 	<table border="1"> <tr> <td><b>22</b></td> <td>22,000</td> </tr> </table>	<b>22</b>	22,000
<b>L</b>	± 0,025	± 0,025	siehe see Tab. 4							
<b>22</b>	22,000									
<b>P</b>  108°	<b>G</b> 30°	<table border="1"> <tr> <td><b>M</b></td> <td>siehe see Tab. 5</td> <td>± 0,13</td> <td>siehe see Tab. 4</td> </tr> </table>	<b>M</b>	siehe see Tab. 5	± 0,13	siehe see Tab. 4	<b>R</b> 	<table border="1"> <tr> <td><b>25</b></td> <td>25,400</td> </tr> </table>	<b>25</b>	25,400
<b>M</b>	siehe see Tab. 5	± 0,13	siehe see Tab. 4							
<b>25</b>	25,400									
<b>R</b>  -	<b>N</b> 0°	<table border="1"> <tr> <td><b>N</b></td> <td>siehe see Tab. 5</td> <td>± 0,025</td> <td>siehe see Tab. 4</td> </tr> </table>	<b>N</b>	siehe see Tab. 5	± 0,025	siehe see Tab. 4	<b>T (40° - 60°)</b> 	<table border="1"> <tr> <td><b>31</b></td> <td>31,750</td> </tr> </table>	<b>31</b>	31,750
<b>N</b>	siehe see Tab. 5	± 0,025	siehe see Tab. 4							
<b>31</b>	31,750									
<b>S</b>  90°	<b>P</b> 11°	<table border="1"> <tr> <td><b>U</b></td> <td>siehe see Tab. 5</td> <td>± 0,13</td> <td>siehe see Tab. 4</td> </tr> </table>	<b>U</b>	siehe see Tab. 5	± 0,13	siehe see Tab. 4	<b>U (40° - 60°)</b> 	<table border="1"> <tr> <td><b>38</b></td> <td>38,100</td> </tr> </table>	<b>38</b>	38,100
<b>U</b>	siehe see Tab. 5	± 0,13	siehe see Tab. 4							
<b>38</b>	38,100									
<b>T</b>  60°	<b>O</b>	<table border="1"> <tr> <th colspan="2">Tab. 4: d</th> <th rowspan="2">J, K, L, M, N</th> <th rowspan="2">U</th> </tr> <tr> <th>über (over)</th> <th>bis (up to)</th> </tr> </table>	Tab. 4: d		J, K, L, M, N	U	über (over)	bis (up to)	<b>V</b>  35°	
Tab. 4: d		J, K, L, M, N	U							
über (over)	bis (up to)									
<b>V</b>  35°	Normalfreiwinkel, die eine besondere Beschreibung erfordern. <i>(Normal clearance angles, which require a special description.)</i>	<table border="1"> <tr> <td>3,9</td> <td>10,0</td> <td>± 0,05</td> <td>± 0,08</td> </tr> </table>	3,9	10,0	± 0,05	± 0,08	<b>W</b> 			
3,9	10,0	± 0,05	± 0,08							
<b>W</b>  80°	Der Eckenwinkel ist bei ungleichwinkligen Grundformen immer der kleinere Winkel. <i>(The corner angle is in the case of not equiangular basic forms always the smaller angle.)</i>	<table border="1"> <tr> <td>10,0</td> <td>15,0</td> <td>± 0,08</td> <td>± 0,13</td> </tr> </table>	10,0	15,0	± 0,08	± 0,13	<b>X</b> mit Besonderheit nach Zeichnung <i>(with special feature acc. to drawing)</i>			
10,0	15,0	± 0,08	± 0,13							
<b>X</b> mit Besonderheit nach Zeichnung <i>(with special feature acc. to drawing)</i>		<table border="1"> <tr> <td>15,0</td> <td>20,0</td> <td>± 0,10</td> <td>± 0,18</td> </tr> </table>	15,0	20,0	± 0,10	± 0,18	<b>Y</b> 			
15,0	20,0	± 0,10	± 0,18							
<b>Y</b>  80°		<table border="1"> <tr> <td>20,0</td> <td>26,0</td> <td>± 0,13</td> <td>± 0,25</td> </tr> </table>	20,0	26,0	± 0,13	± 0,25	<b>Z</b> 			
20,0	26,0	± 0,13	± 0,25							
<b>Z</b>  80°		<table border="1"> <tr> <td>26,0</td> <td>32,0</td> <td>± 0,15</td> <td>± 0,25</td> </tr> </table>	26,0	32,0	± 0,15	± 0,25	<b>AA</b> 			
26,0	32,0	± 0,15	± 0,25							
<b>AA</b>  80°		<table border="1"> <tr> <td>32,0</td> <td>38,0</td> <td>± 0,20</td> <td>± 0,38</td> </tr> </table>	32,0	38,0	± 0,20	± 0,38	<b>BB</b> 			
32,0	38,0	± 0,20	± 0,38							

04 Dicke (Thickness)		PD Schneidenecke (Cutting edge corner)		S Schneidenausführung 1) (Cutting edge type 1)		R Schneidrichtung 1) (Direction of cut 1)		- BP LMT-Norm LMT-Standard																							
		Für Radiusplatten (For radius inserts)						ALC Al-Geometrie (Al geometry)																							
S		Eckradius-r (Corner radius-r)		scharfkantig (sharp-edged)		R		ALM Al-Geometrie, Formenbau (Al geometry die and mould)																							
02	2,38	00	scharfkantig (sharp-edged)			nur rechtsschneidend (RH cut only)		BM Geometrie für rostfreien Stahl (Geometry for stainless steel)																							
03	3,18	02	0,2	gerundet (rounded)		L		BP Hochleistungsgeometrie für Stahl (High performance geometry for steel)																							
T3	3,97	04	0,4					Beispiel (Example):																							
04	4,76	08	0,8	gefäst (chamfered)		nur linksschneidend (LH cut only)		<table border="1"> <tr> <td></td> <td>A</td> <td>P</td> <td>K</td> <td>T</td> <td>16</td> <td>04</td> <td>PD</td> <td>S</td> <td>R</td> <td>-BP</td> </tr> <tr> <td>#</td> <td>1</td> <td>2</td> <td>3</td> <td>4</td> <td>5</td> <td>6</td> <td>7</td> <td>8</td> <td>9</td> <td>10</td> </tr> </table>			A	P	K	T	16	04	PD	S	R	-BP	#	1	2	3	4	5	6	7	8	9	10
	A	P	K	T	16	04	PD	S	R	-BP																					
#	1	2	3	4	5	6	7	8	9	10																					
05	5,56	12	1,2	gefäst und gerundet (chamfered & rounded)		N		1 Grundform (Basic form) rhomboid																							
06	6,35	16	1,6					2 Freiwinkel (Clearance angle) 11°																							
07	7,94	20	2,0	doppelgefäst (double chamfered)		rechts- und linksschneidend (RH and LH cut)		3 Toleranzen (Tolerances) m ± 0,013 mm s ± 0,025 mm d ± 0,05 mm																							
08	8,00	usw. etc.				1) Die Anwendung dieser Kennbuchstaben ist freigestellt. 1) The use of these reference letters is left open.		4 Befestigung (Fixing) Spanfläche (Cutting face) Kegelschraube (fixation screw) einseitig (one side)																							
09	9,52	Für Fasenplatten Planschneiden (For chamfered insert face milling)		K				5 Schneidenecke (Cutting edge corner) 90° Fase (chamfer)																							
		Einstellwinkel (Setting angle) $\chi_r$		P				6 Dicke (Thickness) 4,76 mm																							
		A 45°		D				7 Schneidenecke (Cutting edge corner) 90° Fase (chamfer)																							
		D 60°		S				8 Schneidenecke (Cutting edge corner) gefäst, gerundet (chamfered, rounded)																							
		E 75°		K				9 Schneidenecke (Cutting edge corner) rechts schneidend (righthand cutting)																							
		F 85°		P				10 Interne Bezeichnung (Internal designation) Spanflächen-BP= topographie (Geometry)																							
		P 90°		P																											
		Z Sonder (Special)		P																											
		Frei der Planschneide (Clearance of face milling edge)		P																											
		$\alpha_n$		P																											
		A 3°		P																											
		B 5°		P																											
		C 7°		P																											
		D 15°		P																											
		E 20°		P																											
		F 25°		P																											
		G 30°		P																											
		N 0°		P																											
		P 11°		P																											
		Z Sonder (Special)		P																											
		MO Rundwendeplatte metrisch (Round insert metric)		P																											
		00 Rundwendeplatte Zoll (Round insert inch)		P																											

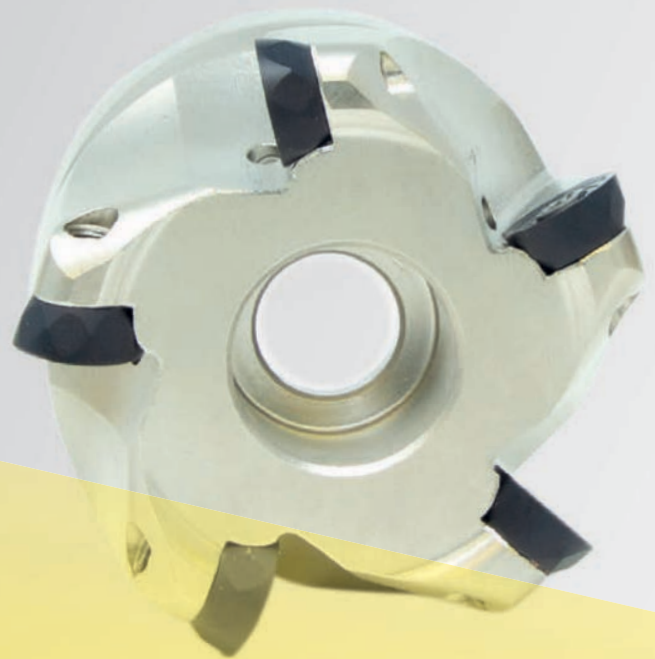

**VHM SCHWARZ Präzisionswerkzeuge GmbH**

Lilienthalstr.3

70825 Korntal-Münchingen, Germany

Tel.: + 49 (0) 711 /51 87 88 10

Fax: + 49 (0) 711 /51 87 88 06

[www.vhm-schwarz.com](http://www.vhm-schwarz.com)

[info@vhm-schwarz.com](mailto:info@vhm-schwarz.com)